

CLOGGING INDICATOR

Series AE (electrical / visual-electrical, block execution)

Sheet No.
1609 H

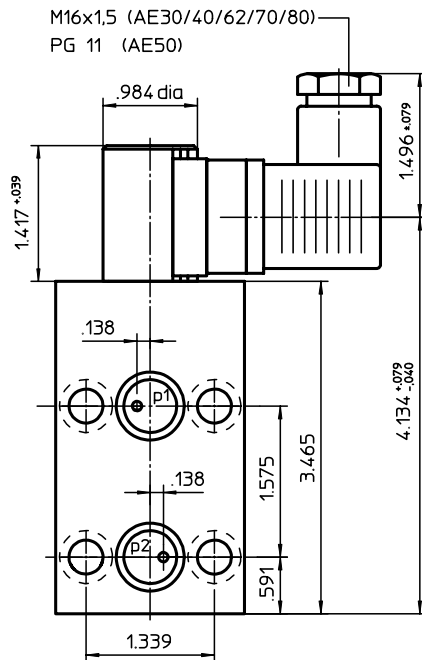
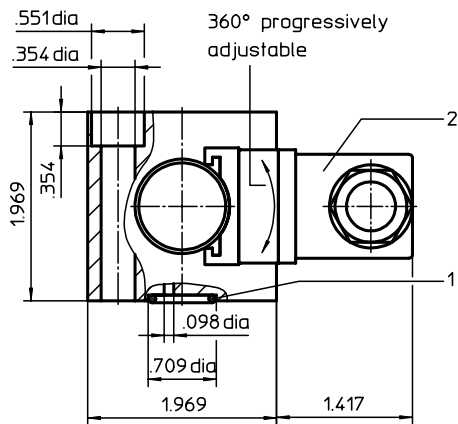

1. Clogging indicator AE

1.1. Type index: (ordering example)

AE. 30. 1,5. P. -. B. -

1	2	3	4	5	6	7
---	---	---	---	---	---	---

- 1 series:**
AE = clogging indicator, electrical / visual-electrical
- 2 version:**
30-80 = see table below
- 3 indicator-pressure difference: Δp-nominal**
1,5 = 22 PSI
2,5 = 36 PSI
5,0 = 73 PSI
- 4 sealing material:**
P = Nitrile (NBR)
V = Viton (FPM)
- 5 material: (block)**
- = standard
VA = stainless steel
- 6 execution:**
B = block execution
- 7 damper:**
- = standard with hydraulic damper
1 = without hydraulic damper

2. Technical data:

- temperature ranges
- operating temperature: + 14°F to +176°F (for a short time +212°F)
- resistant to compression: -22°F to +212°F
- survival temperature: -40°F to +212°F
- max. operating pressure: 6000 PSI
- max. pressure difference: 2320 PSI

version	luminous indication	contact	voltage	max. rupturing capacity (resistive load)	max. switching current (resistive load)	connection protection
30	-	contact maker and contact breaker 175V DC 125V AC	3 VA 3 Watt	0,25 A 0,25 A	line adapter according to DIN 43650-designA/ISO4400
40	-	 175V DC 230V AC	20 VA 10 Watt	1,0 A 0,5 A	
50	1x LED ¹⁾		120V AC/DC	3 Watt/VA	0,025 A with 120V AC/DC	
62	1x LED		110...230V AC/DC	20 Watt/VA	0,180 A with 110V AC/DC 0,090 A with 230V AC/DC	IP 65 according to DIN EN 60529
70	2x LED		24V DC	3 VA	0,080 A with 24V DC	
80	2x LED		24V DC	20 VA	0,750 A with 24V DC	

¹⁾ LED = light emitting diode

3. Spare parts:

item	qty.	designation	dimension	article-no.	type
1	2	O-ring	14 x 2	304342 (NBR)	versions 30 - 80
				304722 (FPM)	
2	1	line adapter	DIN 43650-designA/ISO4400	312492	versions 30 and 40
	1	line adapter with LED 24V		315012	versions 70 and 80
	1	line adapter with LED 120V		315010	version 50
	1	line adapter with LED 110...230V		332235	version 62

4. Symbols:

hydraulic-electrical symbol

connection configuration for LED

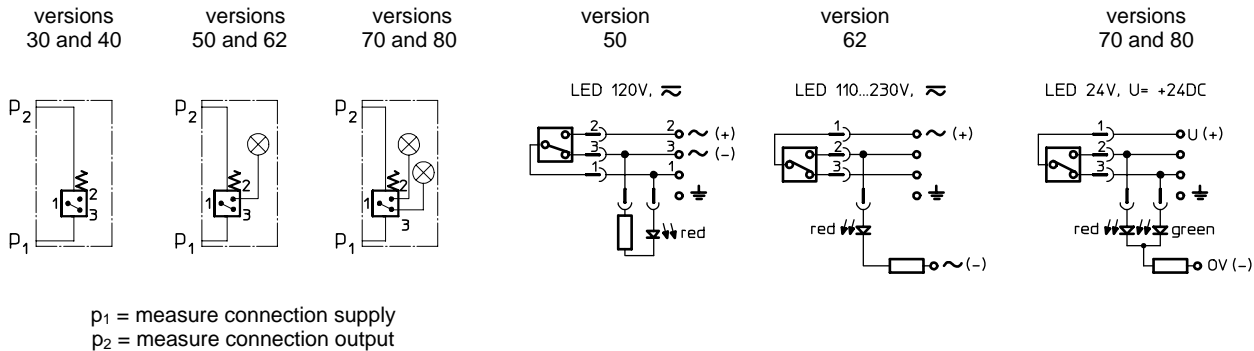

5. Description:

The AE 30 and AE 40 pollution indicators are electrical differential pressure indicators. The AE 50 to AE 80 pollution indicators are combined optical and electrical differential pressure indicators. These differential pressure indicators can be fitted to all pressure filters $p \leq 6000$ PSI for which there is a corresponding assignment on the relevant dimension drawing. As the degree of pollution of the filter element rises, so the difference between the entry pressure p_1 and the exit pressure p_2 of the filter increases. Depending on this pressure difference and irrespective of the operating pressure, in the pollution indicators

- AE 30 and AE 40, two electrical signals (contact maker/contact breaker) are triggered
- AE 50 and AE 62, two electrical signals (contact maker/contact breaker) are triggered and one optical signal is formed
- AE 70 and AE 80, two electrical signals (contact maker/contact breaker) are triggered and two optical signals are formed.

A metering piston subjected to the entry and exit pressure moves against a metering spring according to the pressure differential. Depending on the path, a permanent magnet integrated in the metering piston activates a reed contact (electromagnetic switch) and triggers the electrical signal. The electrical and optical indication is effected as a digital signal at the given switching pressure. Versions 50 to 80 of the pollution indicator are fitted with additional LED displays. The optical LED signal becomes visible according to the selected version in the translucent cover plate of the line box on the pollution indicator.

In the pollution indicators

- AE 50 and AE 62, the red LED signals that the filter element needs to be changed
- AE 70 and AE 80, the green LED signals the normal operating state (filter element not yet polluted to an unacceptable level), while the red LED signals that the filter element needs to be changed.

6. Operating instructions:

Normally filters are supplied with mounted clogging indicators.

It is necessary to make sure the availability and the right positioning of sealing parts O-ring 14 x 2 as well as a dirt-free mounting. The electrical contacts are to be connected according to the graphical symbol shown on the type plate of the clogging indicator.

7. Maintenance:

The device is maintenance-free, however, note that no cleaning fluids and solvents get on the transparent cap of the optical indicator.