

RETURN LINE FILTER, with breather filter
Series TEFB 55-120 DN 16-25 PN 10

views TEFB 55, 70

view TEFB 120

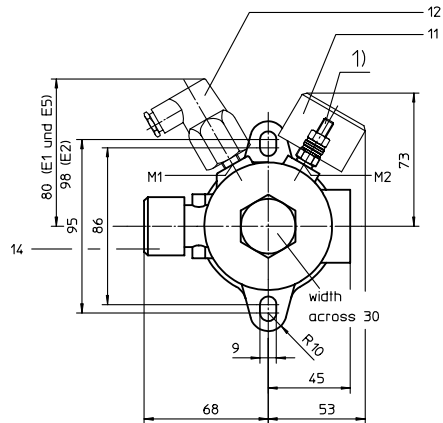
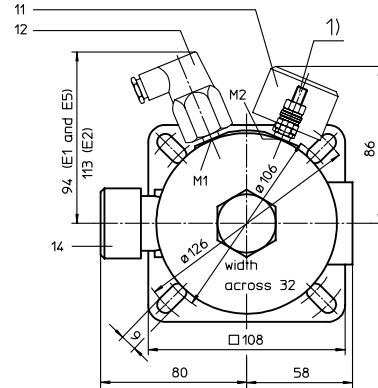
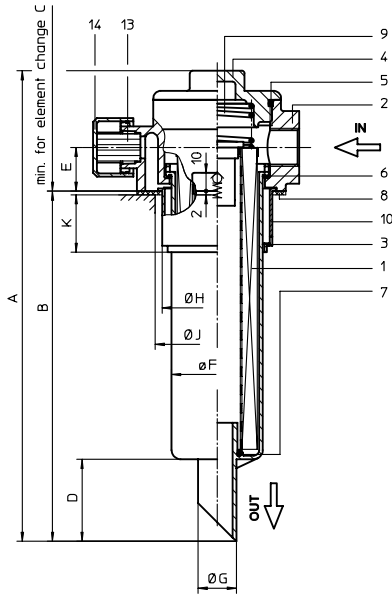

1) connection for the potential equalisation, only for application in the explosive area

When equipped with one clogging indicator use preferably connection M2.

2. Dimensions:

type	connection	A	B	C	D	E	F	G	H	J	K	weight kg	volume tank
TEFB 55	G ½	258	192	270	45	24	52	21	60,5	61	31,5	1	0,3 l
TEFB 70	G ¾	258	192	270	45	24	52	21	60,5	61	31,5	1	0,3 l
TEFB 120	G1	284	208	300	65	30	70	24	78,5	79	42	1,5	0,6 l

1. Type index:

1.1. Complete filter: (ordering example)

TEFB. 120. 10VG. 16. S. P. -. G. 5. -. E1. O. 1

1	2	3	4	5	6	7	8	9	10	11	12	13
---	---	---	---	---	---	---	---	---	----	----	----	----

- 1 series:
TEFB = tank-mounted return-line filter with breather filter
- 2 nominal size: 55, 70, 120
- 3 filter-material and filter-fineness:
80 G = 80 µm, 40 G = 40 µm, 25 G = 25 µm stainless steel wire mesh,
25 VG = 20 µm_(c), 16 VG = 15 µm_(c), 10 VG = 10 µm_(c), 6 VG = 7 µm_(c), 3 VG = 5 µm_(c) Interpor fleece (glass fibre)
25 P = 25 µm, 10 P = 10 µm paper
- 4 resistance of pressure difference for filter element:
16 = Δp 16 bar
- 5 filter element design:
E = without by-pass valve
S = with by-pass valve Δp2,0 bar
- 6 sealing material:
P = Nitrile (NBR)
V = Viton (FPM)
- 7 filter element specification: (see catalog)
- = standard
VA = stainless steel
IS06 = see sheet-no. 31601
- 8 connection:
G = thread connection according to DIN 3852, T2
- 9 connection size:
3 = G ½ TEFB 55
4 = G ¾ TEFB 70
5 = G1 TEFB 120
- 10 filter housing specification: (see catalog)
- = standard
IS06 = see sheet-no. 31605
IS11 = see sheet-no. 40530
- 11 clogging indicator at M1:
- = without
O = visual, see sheet-no. 1616
E1 = pressure switch, see sheet-no. 1616
E2 = pressure switch, see sheet-no. 1616
E5 = pressure switch, see sheet-no. 1616
PA = potential equalisation
- 12 clogging indicator at M2:
possible indicators see position 11 of the type index
- 13 oil separator:
- = without
1 = with oil separator

1.2. Filter element: (ordering example)

01E. 120. 10VG. 16. S. P. -

1	2	3	4	5	6	7
---	---	---	---	---	---	---

- 1 series:
01E. = filter element according to INTERNORMEN factory specification
- 2 nominal size: 70, 120
- 3 - 7 see type index-complete filter

Changes of measures and design are subject to alteration!



Friedensstrasse 41, 68804 Altlusheim, Germany

phone +49 - (0)6205 - 2094-0 e-mail sales@internormen.com
fax +49 - (0)6205 - 2094-40 url www.internormen.com



3. Spare parts:

item	qty.	designation	dimension and article-no.		
			TEFB 55	TEFB 70	TEFB 120
1	1	filter element		01E. 70	01E. 120
2	1	filter head	305314	305315	304743
3	1	filter bowl		304595	303041
4	1	screw plug		M 60 x 2	M 82 x 2
5	1	O-ring		56 x 3	75 x 3
				305072 (NBR)	302215 (NBR)
				305322 (FPM)	304729 (FPM)
6	1	O-ring		50 x 2,5	68 x 4
				305239 (NBR)	303037 (NBR)
				305321 (FPM)	313046 (FPM)
7	1	O-ring		22 x 3	24 x 3
				304387 (NBR)	303038 (NBR)
				304931 (FPM)	304397 (FPM)
8	1	gasket (filter without oil separator)		2 thick	3 thick
				307706	303039
9	1	gasket (filter with oil separator)		2 thick	3 thick
				306786	303039
9	1	spring		DA = 40	DA = 52
10	1	oil separator		304982	302144
11	1	clogging indicator, visual		O	301721
12	1	pressure switch, electrical		E1, E2 or E5	see sheet-no. 1616
13	1	filter element breather		01BFE. 70	01BFE. 120
14	1	protection cap		305312	303048

4. Description:

Return-line filters in the TEFB series are suitable for a working pressure up to 10 bar. Pressure peaks will be absorbed by a sufficient margin of safety. The TEFB-filters are directly mounted to the reservoir and connected to the return-line. No connection is needed for the built-in air filter. The air filter has a 10 µm throw-away element. The filter element consists of a star-shaped, pleated filter material which is supported on the inside by a perforated core tube and is bonded to the end caps with a high-quality adhesive. The flow is from outside to inside. Filters finer than 40 µm should use throw-away elements made of paper or Interpor fleece (glass fibre). Filter elements as fine as 5 µm (α) are available; finer filter elements on request. INTERNORMEN-Filters can be used for petroleum-based fluids, HW emulsions, water glycols, most synthetic fluids and lubrication fluids. Consult factory for specific fluid applications. INTERNORMEN-Filters elements are known as stable elements which have excellent filtration capabilities and a high dirt retaining capacity, therefore having a long service life. Due to its practical design, the return-line filter is easy to service. When changing the filter element a detachable connection between the filter head and the filter bowl prevents a flow back of dirty oil into the tank.

5. Technical data:

temperature range: - 10°C to + 80°C (for a short time + 100°C)
operating medium: mineral oil, other media on request
max. operating pressure: 10 bar
opening pressure by-pass valve: 2,0 bar
line adapter: thread connection according to DIN 3852, T2
housing material standard: filter head AL, filter cover / filter bowl glass fibre reinforced polyamide
housing material IS11, category M2: filter head GG, filter cover steel, filter bowl carbon fibre reinforced polyamide
housing material IS11, category 2: filter head AL, filter cover / filter bowl carbon fibre reinforced polyamide
sealing material: Nitrile (NBR) or Viton (FPM), other materials on request
installation position: vertical

Classified under the Pressure Equipment Directive 97/23/EC for mineral oil (fluid group 2), Article 3, Para. 3.
Classified under ATEX Directive 94/9/EC according to specific application (see questionnaire sheet-no. 34279-4).

6. Symbols:

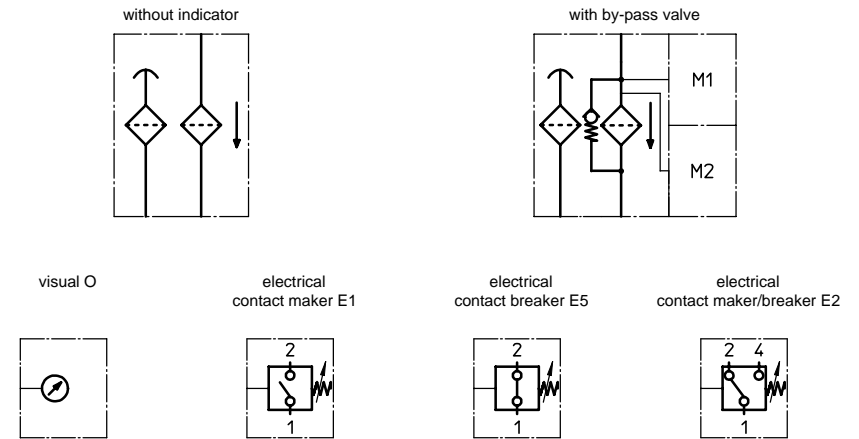

7. Pressure drop flow curves:

Precise flow rates see 'INT-Expert-System Filter', respectively Δp- curves; depending on filter fineness and viscosity.

8. Test methods:

Filter elements are tested according to the following ISO standards:

- ISO 2941 Verification of collapse/burst resistance
- ISO 2942 Verification of fabrication integrity
- ISO 2943 Verification of material compatibility with fluids
- ISO 3723 Method for end load test
- ISO 3724 Verification of flow fatigue characteristics
- ISO 3968 Evaluation of pressure drop versus flow characteristics
- ISO 16889 Multi-pass method for evaluating filtration performance