

RETURN LINE FILTER

Series TEFB 210-310 DN 25 PN 10

Sheet No.
1062 F

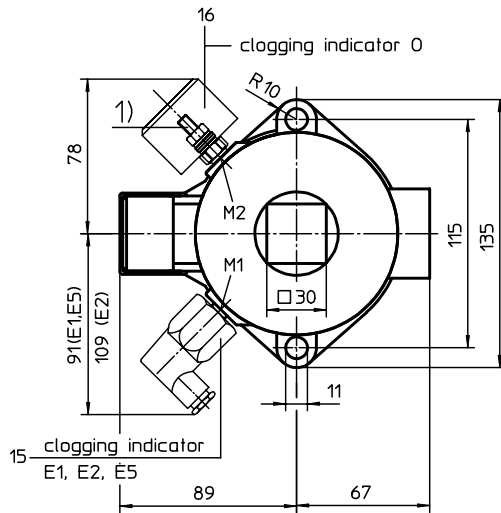
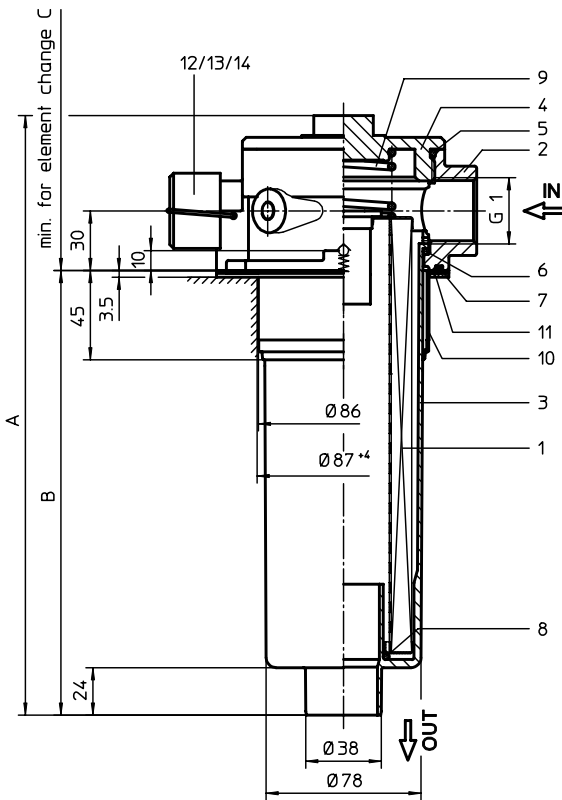

¹⁾ connection for the potential equalisation, only for application in the explosive area

When equipped with one clogging indicator use preferably connection M2.

1. Type index:

1.1. Complete filter: (ordering example)

TEFB. 210. 10VG. 16. S. P. -. G. 5. -. E1. O. 1

1	2	3	4	5	6	7	8	9	10	11	12	13
---	---	---	---	---	---	---	---	---	----	----	----	----

1 series:

TEFB = tank-mounted return-line-filter with breather filter

2 nominal size: 210, 310

3 filter-material and filter-fineness:

80 G = 80 μm , 40 G = 40 μm , 25 G = 25 μm
stainless steel wire mesh
25 VG = 20 $\mu\text{m}_{(c)}$, 16 VG = 15 $\mu\text{m}_{(c)}$, 10 VG = 10 $\mu\text{m}_{(c)}$,
6 VG = 7 $\mu\text{m}_{(c)}$, 3 VG = 5 $\mu\text{m}_{(c)}$ Interpor fleece (glass fibre)
25 P = 25 μm , 10 P = 10 μm paper

4 resistance of pressure difference for filter element:

16 = Δp 16 bar

5 filter element design:

E = without by-pass valve
S = with by-pass valve Δp 2,0 bar

6 sealing material:

P = Nitrile (NBR)
V = Viton (FPM)

7 filter element specification: (see catalog)

- = standard
VA = stainless steel
IS06 = see sheet-no. 31601

8 connection:

G = thread connection according to DIN 3852, T2

9 connection size:

5 = G 1

10 filter housing specification: (see catalog)

- = standard
IS06 = see sheet-no. 31605
IS11 = see sheet-no. 40530

11 clogging indicator at M1:

- = without
O = visual, see sheet-no. 1616
E1 = pressure switch, see sheet-no. 1616
E2 = pressure switch, see sheet-no. 1616
E5 = pressure switch, see sheet-no. 1616
PA = potential equalisation

12 clogging indicator at M2:

possible indicators see position 11 of the type index

13 oil separator:

- = without
1 = with oil separator

1.2. Filter element: (ordering example)

01E. 210. 10VG. 16. S. P. -

1	2	3	4	5	6	7
---	---	---	---	---	---	---

1 series:

01E. = filter element according to INTERNORMEN factory specification

2 nominal size: 210, 320

3 - 7 see type index complete filter

2. Dimensions:

type	A	B	C	weight kg	volume tank
TEFB 210	302	224	350	2,1	1,0 l
TEFB 310	387	309	435	2,3	1,4 l

3. Spare parts:

item	qty.	designation	dimension		article-no.	
			TEFB 210	TEFB 310		
1	1	filter element	01.E 210	01E. 320		
2	1	filter head	TNR 100		313952	
3	1	filter bowl	NG 210	NG 310	304518	305471
4	1	filter cover	M 92 x 3		317014	
5	1	O-ring	82 x 3,5		304403 (NBR)	308745 (FPM)
6	1	O-ring	75 x 3		302215 (NBR)	304729 (FPM)
7	1	O-ring	95 x 3		305808 (NBR)	304828 (FPM)
8	1	O-ring	40 x 3		304991 (NBR)	304997 (FPM)
9	1	spring	DA = 52		305053	
10	1	oil separator				
11	1	gasket (with execution oil separator)	2 thick		325389	
12	1	filter element breather	01BFE. 120		301866	
13	1	protection cap			303048	
14	1	clip			303046	
15	1	clogging indicator electrical	E1, E2 or E5		see sheet-no. 1616	
16	1	clogging indicator visual	O		301721	

4. Description:

Return-line filters in the TEFB series are suitable for a working pressure up to 10 bar. Pressure peaks will be absorbed by a sufficient margin of safety. The TEFB-filters are directly mounted to the reservoir and connected to the return-line. No connection is needed for the build-in air filter. The air filter has a 10 µm throw-away element. The filter element consists of a star-shaped, pleated filter material which is supported on the inside by a perforated core tube and is bonded to the end caps with a high-quality adhesive. The flow is from outside to inside. Filters finer than 40 µm should use throw-away elements made of paper or Interpor fleece (glass fibre). Filter elements as fine as 5 µm_(c) are available; finer filter elements on request.

INTERNORMEN-Filters can be used for petroleum-based fluids, HW emulsions, water glycols, most synthetic fluids and lubrication fluids. Consult factory for specific fluid applications.

INTERNORMEN-Filters elements are known as stable elements which have excellent filtration capabilities and a high dirt retaining capacity, therefore having a long service life. Due to its practical design, the return-line filter is easy to service.

When changing the filter element a detachable connection between the filter head and the filter bowl prevents a flow back of dirty oil into the tank.

5. Technical data:

temperature range:	-10°C to +80°C (for a short time +100°C)
operating medium:	mineral oil, other media on request
max. operating pressure:	10 bar
opening pressure by-pass valve:	2,0 bar
connection system:	thread connection according to DIN 3852, T2
housing material standard:	filter head AL, filter cover / filter bowl glass fibre reinforced polyamide
housing material IS11, category M2:	filter head GG, filter cover steel, filter bowl carbon fibre reinforced polyamide
housing material IS11, category 2	filter head AL, filter cover / filter bowl carbon fibre reinforced polyamide
sealing material:	Nitrile (NBR) or Viton (FPM), other materials on request
installation position:	vertical

Classified under the Pressure Equipment Directive 97/23/EC for mineral oil (fluid group 2), Article 3, Para. 3.
Classified under ATEX Directive 94/9/EC according to specific application (see questionnaire sheet-no. 34279-4).

6. Symbols:

without indicator

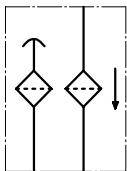

with by-pass valve

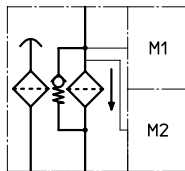

visual O



electrical contact maker E1



electrical contact breaker E5



electrical contact maker/breaker E2



7. Pressure drop flow curves:

Precise flow rates see 'INT-Expert-System Filter', respectively Δp -curves; depending on filter fineness and viscosity.

8. Test methods:

Filter elements are tested according to the following ISO standards:

- ISO 2941 Verification of collapse/burst resistance
- ISO 2942 Verification of fabrication integrity
- ISO 2943 Verification of material compatibility with fluids
- ISO 3723 Method for end load test
- ISO 3724 Verification of flow fatigue characteristics
- ISO 3968 Evaluation of pressure drop versus flow characteristics
- ISO 16889 Multi-pass method for evaluating filtration performance