

RETURN LINE FILTER

Series TEF 4801-7201 DN 150-200 PN 10

Sheet No.
1058 D

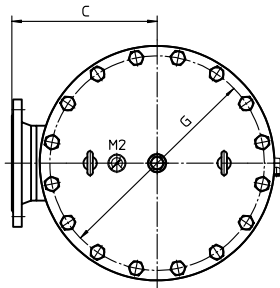
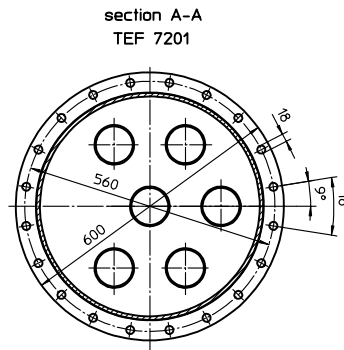
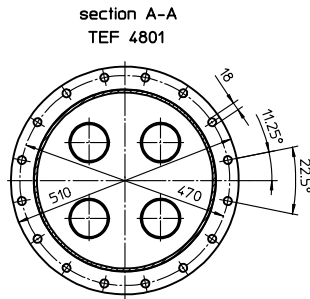
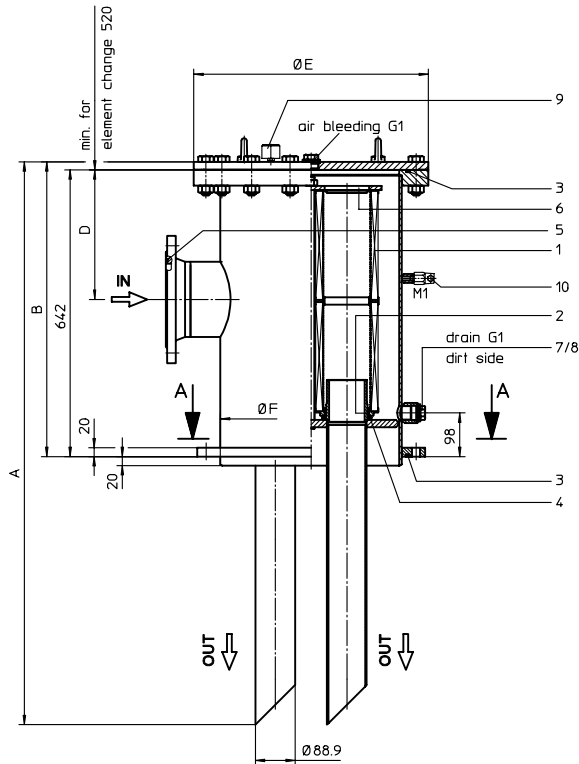

When equipped with one clogging indicator use preferably connection M1.

2. Dimensions:

type	connection	A	B	C	D	E	F	G	weight	volume tank
TEF 4801	DN 150	1260	660	325	290	525	406	480	193	75,0 l
TEF 7201	DN 200	1264	664	400	280	615	508	570	252	117,0 l

1. Type index:

1.1. Complete filter: (ordering example)

TEF. 4801. 10VG. 10. S. P. -. FD3. D. -. E1. O

1	2	3	4	5	6	7	8	9	10	11	12
---	---	---	---	---	---	---	---	---	----	----	----

- 1 series:
TEF = tank-mounted return-line filter
- 2 nominal size: 4801, 7201
- 3 filter-material and filter-fineness:
80 G = 80 µm, 40 G = 40 µm, 25 G = 25 µm stainless steel wire mesh,
25 VG = 20 µm_(c), 16 VG = 15 µm_(c), 10 VG = 10 µm_(c), 6 VG = 7 µm_(c), 3 VG = 5 µm_(c) Interpor fleece (glass fibre)
25 P = 25 µm, 10 P = 10 µm paper
- 4 resistance of pressure difference for filter element:
10 = Δp 10 bar
- 5 filter element design:
E = without
S = with by-pass valve Δp 2,0 bar
- 6 sealing material:
P = Nitrile (NBR)
V = Viton (FPM)
- 7 filter element specification: (see catalog)
- = standard
VA = stainless steel
ISO6 = see sheet-no. 31601
- 8 connection:
FD3 = flange DIN 2633 with O-ring groove (TEF 4801)
FD13 = flange DIN 2632 with O-ring groove (TEF 7201)
- 9 connection size:
D = DN 150 (TEF 4801)
E = DN 200 (TEF 7201)
- 10 filter housing specification: (see catalog)
- = standard
ISO6 = see sheet-no. 31605
- 11 clogging indicator at M1:
- = without
O = visual see, sheet-no. 1616
E1 = pressure switch, see sheet-no. 1616
E2 = pressure switch, see sheet-no. 1616
E5 = pressure switch, see sheet-no. 1616
- 12 clogging indicator at M2:
possible indicators see position 11 of the type index

1.2. Filter element: (ordering example)

01E. 1201. 10VG. 10. S. P. -

1	2	3	4	5	6	7
---	---	---	---	---	---	---

- 1 series:
01E. = filter element according to INTERNORMEN factory specification
- 2 nominal size: 1201
- 3 - 7 see type index-complete filter

Changes of measures and design are subject to alteration!

internormen
technology

Friedensstrasse 41, 68804 Altlusheim, Germany

phone +49 - (0)6205 - 2094-0 e-mail sales@internormen.com
fax +49 - (0)6205 - 2094-40 url www.internormen.com



3. Spare parts:

item	designation	qty.	dimension and article-no. TEF 4801	qty.	dimension and article-no. TEF 7201
1	filter element	4	01E. 1201	6	01E. 1201
2	O-ring	4	93 x 5 307588 (NBR) 307589 (FPM)	6	93 x 5 307588 (NBR) 307589 (FPM)
3	O-ring	2	429 x 6 308659 (NBR) 310273 (FPM)	2	516 x 6 301962 (NBR) 311474 (FPM)
4	O-ring	4	85 x 10 304386 (NBR) 304541 (FPM)	6	85 x 10 304386 (NBR) 304541 (FPM)
5	O-ring	1	170 x 4 306875 (NBR) 307987 (FPM)	1	225 x 5 308652 (NBR) 311473 (FPM)
6	pressure plate	1	319677	1	327718
7	screw plug	2	G 1 309732		
8	gasket	2	A 33 x 39 308257		
9	clogging indicator, visual	1	O see sheet-no. 1616		
10	pressure switch, electrical	1	E1, E2 oder E5 see sheet-no. 1616		

4. Description:

Return-line filters in the TEF series are suitable for a working pressure up to 10 bar. Pressure peaks will be absorbed by a sufficient margin of safety. The TEF-filters are directly mounted to the reservoir and connected to the return-line. The filter element consists of a star-shaped, pleated filter material which is supported on the inside by a perforated core tube and is bonded to the end caps with a high-quality adhesive. The flow is from outside to inside. Filters finer than 40 µm should use throw-away elements made of paper or Interpor fleece (glass fibre). Filter elements as fine as 5 µm (c) are available; finer filter elements on request. INTERNORMEN-Filters can be used for petroleum-based fluids, HW emulsions, water glycols, most synthetic fluids and lubrication fluids. Consult factory for specific fluid applications. INTERNORMEN-Filters elements are known as stable elements which have excellent filtration capabilities and a high dirt retaining capacity, therefore having a long service life. Due to its practical design, the return-line filter is easy to service. When changing the filter element a detachable connection between the filter head and the filter bowl prevents a flow back of dirty oil into the tank.

5. Technical data:

temperature range:	- 10°C to + 80°C (for a short time + 100°C)
operating medium:	mineral oil, other media on request
max. operating pressure:	10 bar
opening pressure by-pass valve:	2,0 bar
line adapter:	flange connection according to DIN 2633 and DIN 2632
housing material:	c-steel
sealing material:	Nitrile (NBR) or Viton (FPM), other materials on request
installation position:	vertical

Classified under the Pressure Equipment Directive 97/23/EC for mineral oil (fluid group 2), Article 3, Para. 3.
Classified under ATEX Directive 94/9/EC according to specific application (see questionnaire sheet-no. 34279-4).

6. Symbols:

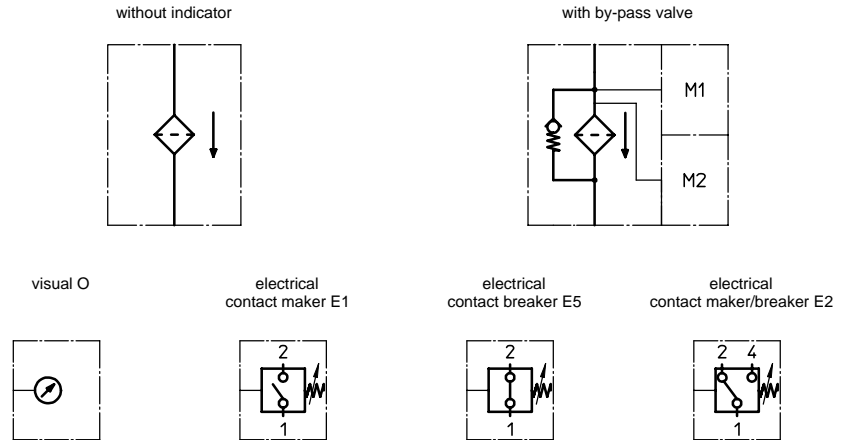

7. Pressure drop flow curves:

Precise flow rates see 'INT-Expert-System Filter', respectively Δp- curves; depending on filter fineness and viscosity.

8. Test methods:

Filter elements are tested according to the following ISO standards:

ISO 2941	Verification of collapse/burst resistance
ISO 2942	Verification of fabrication integrity
ISO 2943	Verification of material compatibility with fluids
ISO 3723	Method for end load test
ISO 3724	Verification of flow fatigue characteristics
ISO 3968	Evaluation of pressure drop versus flow characteristics
ISO 16889	Multi-pass method for evaluating filtration performance