

PRESSURE FILTER

Series LF 251-1100

DN 40-125

PN 32

Sheet No.

1117 L

1. Type index:

1.1. Complete filter: (ordering example)

LF. 401. 10VG. 30. E. P. -. FS. 8. -. -. AE

1	2	3	4	5	6	7	8	9	10	11	12
---	---	---	---	---	---	---	---	---	----	----	----

- 1 series:
LF = in-line filter
- 2 nominal size: 251, 401, 631, 1001, 1100
- 3 filter material and filter-fineness:
80 G = 80 µm, 40 G = 40 µm, 25 G = 25 µm stainless steel wire mesh,
25 VG = 20 µm_(G), 16 VG = 15 µm_(G), 10 VG = 10 µm_(G), 6 VG = 7 µm_(G), 3 VG = 5 µm_(G) Interpor fleece (glass fibre)
- 4 resistance of pressure difference for filter element:
10 = Δp 10 bar (01NR.) 30 = Δp 30 bar (01NL.)
- 5 filter element design:
E = single-end open S = with by-pass valve Δp 2,0 bar
B = both sides open (LF 1001/1100) S1 = with by-pass valve Δp 3,5 bar
- 6 sealing material:
P = Nitrile (NBR)
V = Viton (FPM)
- 7 filter element specification: (see catalog)
- = standard VA = stainless steel IS06 = see sheet-no. 31601 IS07 = see sheet-no. 31602
- 8 connection:
FS = SAE-flange connection 3000 PSI (LF 251-1100)
- 9 connection size:
7 = 1 1/2" (LF 251) 9 = 2 1/2" (LF 631) C = 5" (LF 1100)
8 = 2" (LF 401) A = 3" (LF 1001)
- 10 filter housing specification: (see catalog)
- = standard
IS06 = see sheet-no. 31605
- 11 internal valve:
- = without
S = with by-pass valve Δp 2,0 bar (LF 1001/1100)
S1 = with by-pass valve Δp 3,5 bar (LF 1001/1100)
- 12 clogging indicator or clogging sensor:
- = without
AOR = visual, see sheet-no. 1606
AOC = visual, see sheet-no. 1606
AE = visual-electrical, see sheet-no. 1609
OP = visual, see sheet-no. 1628
OE = visual-electrical, see sheet-no. 1628
VS1 = electronical, see sheet-no. 1607
VS2 = electronical, see sheet-no. 1608

1.2. Filter element: (ordering example)

01NL. 400. 10VG. 30. E. P. -

1	2	3	4	5	6	7
---	---	---	---	---	---	---

- 1 series:
01NL. = standard filter element according to DIN 24550, T3
01NR. = standard-return-line filter element according to DIN 24550, T4
- 2 nominal size: 250, 400, 630 (01NL.), 1000 (01NR.)
- 3 - 7 see type index-complete filter

2. Accessories:

- measure- and bleeder connection, see sheet-no. 1650
- evacuation- and bleeder connection, see sheet-no. 1651
- counter flange, see sheet-no. 1652

Changes of measures and design are subject to alteration!

internormen
technology

Friedensstrasse 41, 68804 Altlusheim, Germany

phone +49 - (0)6205 - 2094-0 e-mail sales@internormen.com
fax +49 - (0)6205 - 2094-40 url www.internormen.com

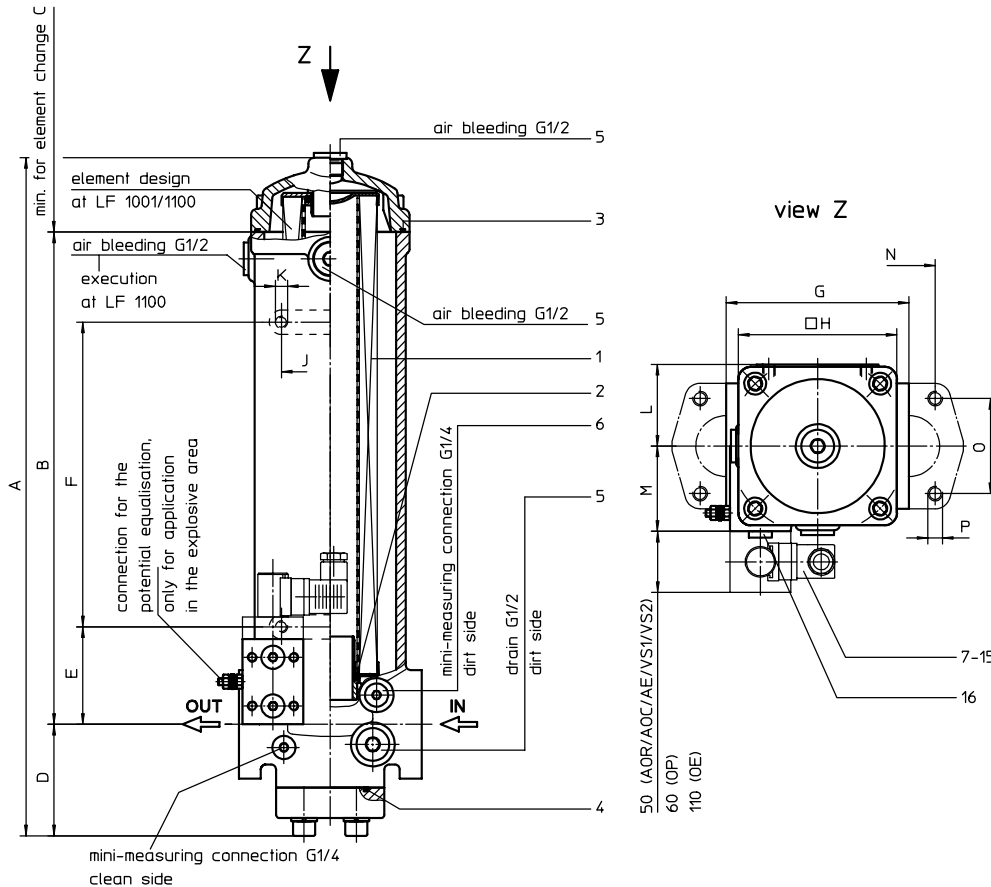

3. Dimensions:

type	LF 251	LF 401	LF 631	LF 1001	LF 1100
connection	SAE 1 1/2"	SAE 2"	SAE 2 1/2"	SAE 3"	SAE 5"
A	354	550	561	583	641
B	254	404	406	404	430
C	260	410	410	410	410
D	39	85	86	100	130
E	80	80	80	90	116
F	-	250	250	250	250
G	140	150	170	220	220
H	130	130	160	205	205
J	80	80	80	116	116
K	M10x12 deep	M10x12 deep	M12x18 deep	M12x18 deep	M12x18 deep
L	67	67	82	106	106
M	72	70	86	106	106
N	35,7	42,9	50,8	62	92
O	70	77,8	89	106,4	152,4
P	M12x19 deep	M12x19 deep	M12x19 deep	M16x24 deep	M16x24 deep
weight kg	16	25	35	45	51
volume tank	2,4 l	3,6 l	5,3 l	11,5 l	11,5 l

4. Spare parts:

item	designation	qty.	dimension and article-no. LF 251	qty.	dimension and article-no. LF 401	qty.	dimension and article-no. LF 631	qty.	dimension and article-no. LF 1001/1100
1	filter element	1	01NL. 250	1	01NL. 400	1	01NL. 630	1	01NR. 1000
2	O-ring	1	40 x 3 304389 (NBR) 304391 (FPM)	1	40 x 3 304389 (NBR) 304391 (FPM)	1	60 x 3,5 304377 (NBR) 304398 (FPM)	1	90 x 4 306941 (NBR) 307031 (FPM)
3	O-ring	1	115 x 3 303963 (NBR) 307762 (FPM)	1	115 x 3 303963 (NBR) 307762 (FPM)	1	125 x 3 306025 (NBR) 307358 (FPM)	1	185 x 4 305593 (NBR) 306309 (FPM)
4	O-ring (LF 401-1001)	-	-	1	56,75 x 3,53 306035 (NBR) 310264 (FPM)	1	69,45 x 3,53 305868 (NBR) 307357 (FPM)	1	85,32 x 3,53 305590 (NBR) 306308 (FPM)
	O-ring (LF 1100)	-	-	-	-	-	-	1	136,12 x 3,53 320162 (NBR) 320163 (FPM)
5	screw plug	3	G ½ 304678	3	G ½ 304678	3	G ½ 304678	3	G ½ 304678
6	screw plug	2	G ¼ 305003						
7	clogging indicator, visual	1	AOR or AOC see sheet-no. 1606						
8	clogging indicator, visual	1	OP see sheet-no. 1628						
9	clogging indicator, visual-electrical	1	OE see sheet-no. 1628						
10	clogging indicator, visual-electrical	1	AE see sheet-no. 1609						
11	clogging sensor, electronical	1	VS1 see sheet-no. 1607						
12	clogging sensor, electronical	1	VS2 see sheet-no. 1608						
13	O-ring	1	15 x 1,5 315357 (NBR) 315427 (FPM)						
14	O-ring	1	22 x 2 304708 (NBR) 304721 (FPM)						
15	O-ring	2	14 x 2 304342 (NBR) 304722 (FPM)						
16	screw plug	2	G ¼ 305003						

item 16 execution only without clogging indicator or clogging sensor

5. Description:

In-line filters of the type LF 251-1100 are suitable for a working pressure up to 32 bar. Pressure peaks are absorbed with a sufficient margin of safety. The filter is mounted in such a way that inlet and outlet are on the same level. It can be used as suction filter, pressure filter and return-line filter. The filter element consists of star-shaped, pleated filter material which is supported on the inside by a perforated core tube and is bonded to the end caps with a high-quality adhesive. The flow direction is from outside to inside. For cleaning (see special leaflet 21070-4 and 34448-4) the mesh element respectively to change the glass fibre element remove the cover and take out the element. Filter finer than 40 µm should use throw-away elements made of paper or Interpor fleece (glass fibre). Filter elements as fine as 5 µm_(c) microns are available; finer filter elements on request. INTERNORMEN-Filter elements are known as elements with a high intrinsic stability and an excellent filtration capability, a high dirt-retaining capacity and a long service life. INTERNORMEN-Filter are suitable for all petroleum based fluids, HW-emulsions, most synthetic hydraulic fluids and lubrication oils. Approvals according to TÜV, and the major „Shipyards Classification Societies“ D.N.V.; B.V.; G.L.; L.R.S.; R.I.N.A.; A.B.S. and others are possible. The internal valve is integrated in the filter cover. After reaching the opening pressure the by-pass valve causes that an unfiltered partial flow passes the filter.

E 1117 L

6. Technical data:

temperature range: -10°C to +80°C (for a short time +100°C)
operating medium: mineral oil, other media on request
max. operating pressure: 32 bar
test pressure: 64 bar
connection system: SAE-flange connection 3000 PSI
housing material: EN-GJS-400-18-LT
sealing material: Nitrile (NBR) or Viton (FPM), other materials on request
installation position: vertical
mini-measuring connection: G ¼
evacuation-or bleeder-connection: G ½

Classified under the Pressure Equipment Directive 97/23/EC for mineral oil (fluid group 2), Article 3, Para. 3.
Classified under ATEX Directive 94/9/EC according to specific application (see questionnaire sheet-no. 34279-4).

7. Symbols:

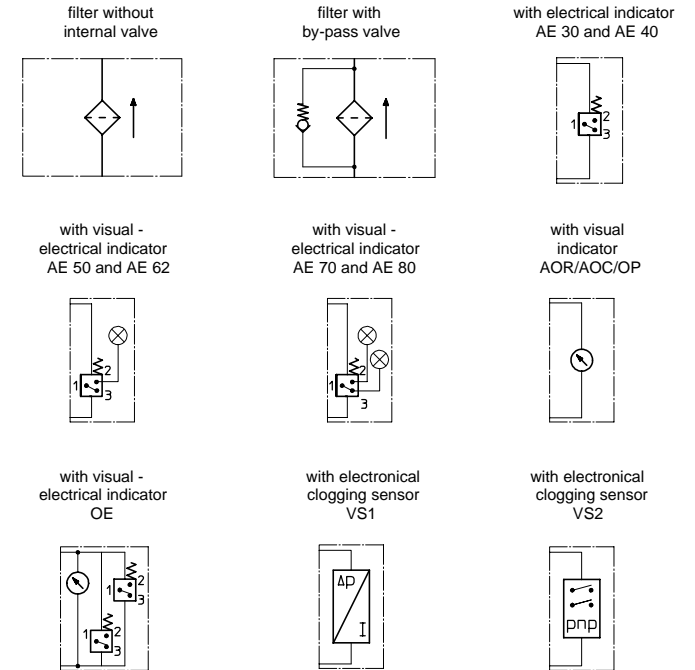

8. Pressure drop flow curves:

Precise flow rates see 'INT-Expert-System Filter', respectively Δp- curves; depending on filter fineness and viscosity.

9. Test methods:

Filter elements are tested according to the following ISO standards:

ISO 2941	Verification of collapse/burst resistance
ISO 2942	Verification of fabrication integrity
ISO 293	Verification of material compatibility with fluids
ISO 3723	Method for end load test
ISO 3724	Verification of flow fatigue characteristics
ISO 3968	Evaluation of pressure drop versus flow characteristics
ISO 16889	Multi-pass method for evaluating filtration performance