

PRESSURE FILTER

Series HPV 60-150 DN 25 PN 420

Sheet No.
1478 E

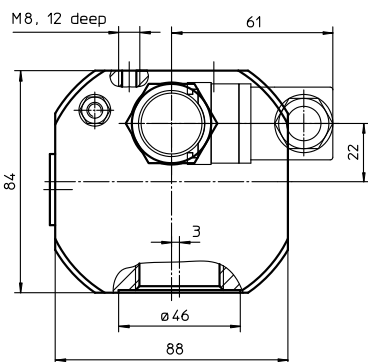
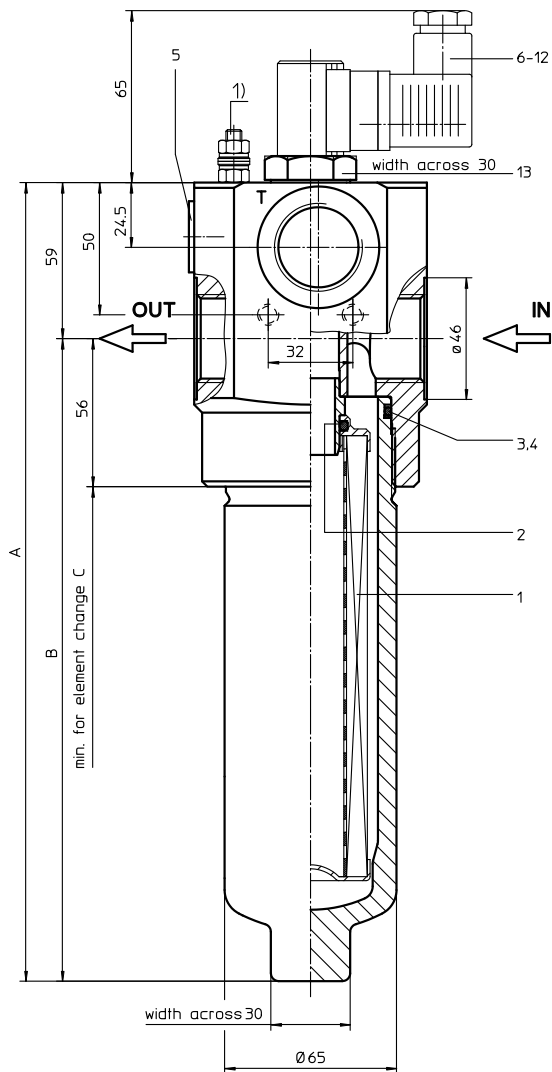

¹⁾ connection for the potential equalisation, only for application in the explosive area

1. Type index:

1.1. Complete filter: (ordering example)

HPV. 90. 10VG. HR. E. P. - G. 5. - D2. AE

1	2	3	4	5	6	7	8	9	10	11	12
---	---	---	---	---	---	---	---	---	----	----	----

- 1 series:**
HPV = pressure filter with differential pressure-valve
- 2 nominal size:** 60, 90, 150
- 3 filter-material and filter-fineness:**
80 G = 80 μm , 40 G = 40 μm , 25 G = 25 μm
stainless steel wire mesh
25 VG = 20 $\mu\text{m}_{(c)}$, 16 VG = 15 $\mu\text{m}_{(c)}$, 10 VG = 10 $\mu\text{m}_{(c)}$,
6 VG = 7 $\mu\text{m}_{(c)}$, 3 VG = 5 $\mu\text{m}_{(c)}$ Interpor fleece (glass fibre)
- 4 resistance of pressure difference for filter element:**
30 = Δp 30 bar
HR = Δp 160 bar (rupture strength Δp 250 bar)
- 5 filter element design:**
E = single-end open
- 6 sealing material:**
P = Nitrile (NBR)
V = Viton (FPM)
- 7 filter element specification:**
- = standard
VA = stainless steel
- 8 connection:**
G = thread connection according to ISO 228
- 9 connection size:**
5 = G 1
- 10 filter housing specification:**
- = standard
- 11 internal valve:**
D1 = differential pressure-valve Δp 3,5 bar
D2 = differential pressure-valve Δp 7,0 bar
- 12 clogging indicator or clogging sensor:**
- = without
AOR = visual, see sheet-no. 1606
AOC = visual, see sheet-no. 1606
AE = visual-electrical, see sheet-no. 1615
VS1 = electrical, see sheet-no. 1617
VS2 = electrical, see sheet-no. 1618

1.2. Filter element: (ordering example)

01E. 90. 10VG. HR. E. P. -

1	2	3	4	5	6	7
---	---	---	---	---	---	---

- 1 series:**
01E. = filter element according to INTERNORMEN specification
- 2 nominal size:** 60, 90, 150
- 3 - 7** see type index-complete filter

2. Dimensions:

type	HPV 60	HPV 90	HPV 150
connection	G 1		
A	237	302	411
B	178	243	352
C	270	335	445
weight kg	6,5	7	8
volume tank	0,3 l	0,4 l	0,6 l

3. Spare parts:

item	qty.	designation	dimension HPV 60 -150	article-no.	
1	1	filter element	01E. 60-150		
2	1	O-ring	22 x 3,5	304341 (NBR)	304392 (FPM)
3	1	O-ring	54 x 3	304657 (NBR)	304720 (FPM)
4	1	support ring	61 x 2,6 x 1	304660	
5	1	screw plug	G ½	304678	
6	1	clogging indicator, visual	AOR or AOC	see sheet-no. 1606	
7	1	clogging indicator, visual-electrical	AE	see sheet-no. 1615	
8	1	clogging sensor, electrical	VS1	see sheet-no. 1617	
9	1	clogging sensor, electrical	VS2	see sheet-no. 1618	
10	1	O-ring	15 x 1,5	315357 (NBR)	315427 (FPM)
11	1	O-ring	22 x 2	304708 (NBR)	304721 (FPM)
12	1	O-ring	14 x 2	304342 (NBR)	304722 (FPM)
13	1	screw plug	20913-4	309817	

item 13 execution only without clogging indicator or clogging sensor

4. Description:

The pressure filters of the series HPV 60-150 are suitable for a working pressure up to 420 bar. The pressure peaks are absorbed by a sufficient margin of safety. The HPV-filter is in-line mounted. The filter element consists of star-shaped, pleated filter material which is supported on the inside by a perforated core tube and is bonded to the end caps with a high-quality adhesive. The flow direction is from outside to the inside. Filter elements are available down to 4µm_(G). INTERNORMEN-Filter elements are known as elements with a high intrinsic stability and an excellent filtration capability, a high dirt-retaining capacity and a long service life. INTERNORMEN-Filter are suitable for all petroleum based fluids, HW-emulsions, most synthetic hydraulic fluids and lubrication oils. INTERNORMEN-Filter elements are available up to a pressure difference resistance of Δp 160 bar and a rupture strength of Δp 250 bar. The differential pressure-valve opens independently of the operating pressure at a chosen differential pressure-valve between IN and OUT and leaves an unfiltered partial-flow flowing from „IN“ to the tank.

5. Technical data:

temperature range:	- 10°C to + 80°C (for a short time + 100°C)
operating medium:	mineral oil, other media on request
max. operating pressure:	420 bar
test pressure:	600 bar
connection system:	thread connection according to ISO 228
housing material:	C-steel
sealing material:	Nitrile (NBR) or Viton (FPM), other materials on request
installation position:	vertical

Classified under the Pressure Equipment Directive 97/23/EC for mineral oil (fluid group 2), Article 3, Para. 3.
Classified under ATEX Directive 94/9/EC according to specific application (see questionnaire sheet-no. 34279-4).

6. Symbols:

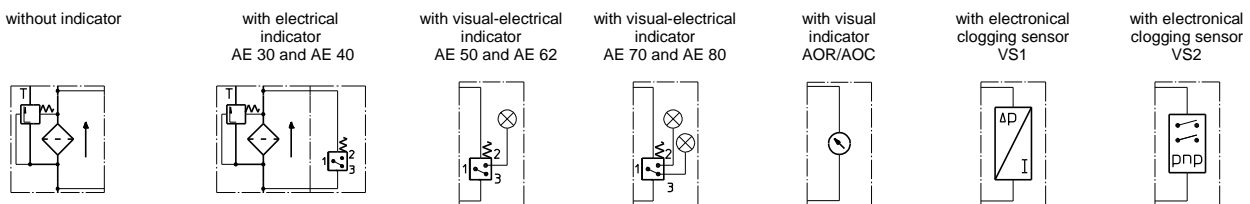

7. Pressure drop flow curves:

Precise flow rates see 'INT-Expert-System Filter' respectively Δp-curves ; depending on filter fineness and viscosity.

8. Test methods:

Filter elements are tested according to the following ISO standards:

ISO 2941	Verification of collapse/burst resistance
ISO 2942	Verification of fabrication integrity
ISO 2943	Verification of material compatibility with fluids
ISO 3723	Method for end load test
ISO 3724	Verification of flow fatigue characteristics
ISO 3968	Evaluation of pressure drop versus flow characteristics
ISO 16889	Multi-pass method for evaluating filtration performance