

PRESSURE FILTER, change-over

Series HDD 170 - 450 DN 40 PN 315

Sheet No.
2514 N

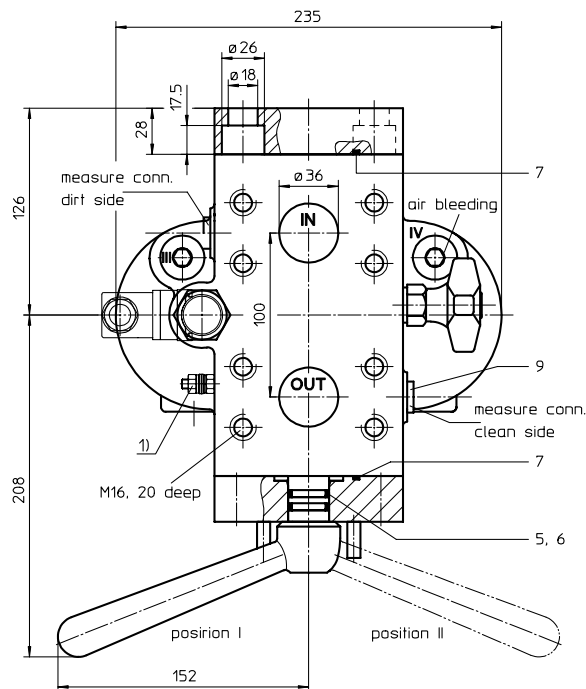
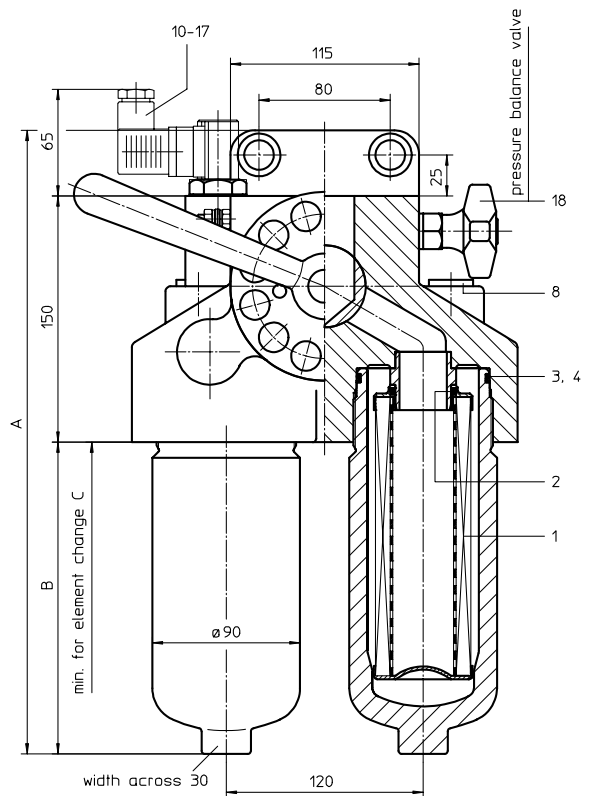

Pos. I: left filter-side in operation
Pos. II: right filter-side in operation

Connection III and IV to be used to bleed filter or to relieve pressure

1) connection for the potential equalisation, only for the application in the explosive area

1. Type index:

1.1. Complete filter: (ordering example)

HDD. 170. 10VG. HR. E. P. - FS. 7. - - AE

1	2	3	4	5	6	7	8	9	10	11	12
---	---	---	---	---	---	---	---	---	----	----	----

- 1 **series:**
HDD = pressure filter, change-over
- 2 **nominal size:** 170, 240, 360, 450
- 3 **filter-material and filter-fineness:**
25 VG = 20 $\mu\text{m}_{(C)}$, 16 VG = 15 $\mu\text{m}_{(C)}$, 10 VG = 10 $\mu\text{m}_{(C)}$,
6 VG = 7 $\mu\text{m}_{(C)}$, 3 VG = 5 $\mu\text{m}_{(C)}$ Interpor fleece (glass fibre)
- 4 **resistance of pressure difference for filter element:**
30 = Δp 30 bar
HR = Δp 160 bar (rupture strength Δp 250 bar)
- 5 **filter element design:**
E = single-end open
- 6 **sealing material:**
P = Nitrile (NBR)
V = Viton (FPM)
- 7 **filter element specification:**
- = standard
VA = stainless steel
- 8 **connection:**
FS = SAE-flange connection 6000 PSI
- 9 **connection size:**
7 = 1 1/2"
- 10 **filter housing specification:**
- = standard
- 11 **internal valve:**
- = without
S1 = with by-pass valve Δp 3,5 bar
S2 = with by-pass valve Δp 7,0 bar
R = reversing valve, $Q \leq 211,008$ l/min
- 12 **clogging indicator or clogging sensor:**
- = without
AOR = visual, see sheet-no. 1606
AOC = visual, see sheet-no. 1606
AE = visual-electrical, see sheet-no. 1615
VS1 = electrical, see sheet-no. 1617
VS2 = electrical, see sheet-no. 1618

1.2. Filter element: (ordering example)

01E. 170. 10VG. HR. E. P. -

1	2	3	4	5	6	7
---	---	---	---	---	---	---

- 1 **series:**
01E. = filter element according to INTERNORMEN factory specification
- 2 **nominal size:** 170, 240, 360, 450
- 3 - 7 see type index-complete filter

2. Accessories:

- measure- and bleeder connection, see sheet-no. 1650

3. Dimensions:

type	connection	A	B	C	weight kg	volume tank
HDD 170	SAE 1 1/2"	380	190	350	39	2x 0,7 l
HDD 240		430	240	400	41	2x 0,9 l
HDD 360		510	320	480	45	2x 1,2 l
HDD 450		615	425	585	50	2x 1,6 l

4. Spare parts:

item	qty.	designation	dimension				article-no.	
			HDD 170 01E.170	HDD 240 01E.240	HDD 360 01E.360	HDD 450 01E.450		
1	2	filter element						
2	2	O-ring	34 x 3,5				304338 (NBR)	304730 (FPM)
3	2	O-ring	75 x 3				302215 (NBR)	304729 (FPM)
4	2	support ring	81 x 2,6 x 1				304581	
5	2	O-ring	18 x 3				304359 (NBR)	304399 (FPM)
6	2	support ring	25 x 2,5 x 0,5				311311	
7	2	O-ring	56 x 3				305072 (NBR)	305322 (FPM)
8	2	screw plug	G ½				304678	
9	2	screw plug	G ¼				305003	
10	1	clogging indicator, visual	AOR or AOC				see sheet-no. 1606	
11	1	clogging indicator, visual-electrical	AE				see sheet-no. 1615	
12	1	clogging sensor, electronical	VS1				see sheet-no. 1617	
13	1	clogging sensor, electronical	VS2				see sheet-no. 1618	
14	1	O-ring	15 x 1,5				315357 (NBR)	315427 (FPM)
15	1	O-ring	22 x 2				304708 (NBR)	304721 (FPM)
16	1	O-ring	14 x 2				304342 (NBR)	304722 (FPM)
17	1	screw plug	20913-4				309817	
18	1	pressure balance valve						

item 17 execution only without clogging indicator or clogging sensor

5. Description:

Duplex pressure filters with change-over valve type HDD are suitable for a working pressure up to 315 bar.

The pressure peaks are absorbed by a sufficient margin of safety. Duplex filters can be serviced without interruption of operation. The upper part has a three-way-change-over valve which allows to change-over the flow from the dirty filter-side to the clean filter-side without interrupting the operation. The change-over procedure does not lead to a cross sectional contraction. Prior to the change-over procedure a built-in pressure balance valve equalizes the housing pressure. After change-over the pressure balance valve is to be closed again. The closed filter-side has to be air-bled by vent III respectively by vent IV. Then change filter element. After screw in the filter bowl the pressure balance has to be opened shortly and the just serviced filter-side has to be air-bled. Filter elements are available down to a filter fineness of 4 $\mu\text{m}_{(c)}$.

INTERNORMEN-Filter elements are known as elements with a high intrinsic stability and an excellent filtration capability, a high dirt-retaining capacity and a long service life.

INTERNORMEN-Filter are suitable for all petroleum based fluids, HW-emulsions, most synthetic hydraulic fluids and lubrication oils.

INTERNORMEN-Filter elements are available with a pressure difference resistance up to Δp 160 bar and a rupture strength up to Δp 250 bar.

The internal valves are integrated into the centering pivot for the filter element. After reaching the opening pressure the by-pass valve causes that an unfiltered partial flow passes the filter. With the reverse valve a protection of the filter element is given when having a reverse flow inside the filter. The reverse flow will not be filtered.

6. Technical data:

temperature range:	-10°C to +80°C (for a short time +100°C)
operating medium:	mineral oil, other media on request
max. operating pressure:	315 bar
test pressure:	410 bar
connection system:	SAE-flange connection 6000 PSI
housing material:	EN-GJS-400-18-LT; C-steel
sealing material:	Nitrile (NBR) or Viton (FPM), other materials on request
installation position:	vertical
mini-measuring connections:	G ¼
air bleeding connections:	G ½

Classified under the Pressure Equipment Directive 97/23/EC for mineral oil (fluid group 2), Article 3, Para. 3.

Classified under ATEX Directive 94/9/EC according to specific application (see questionnaire sheet-no. 34279-4).

7. Symbols:

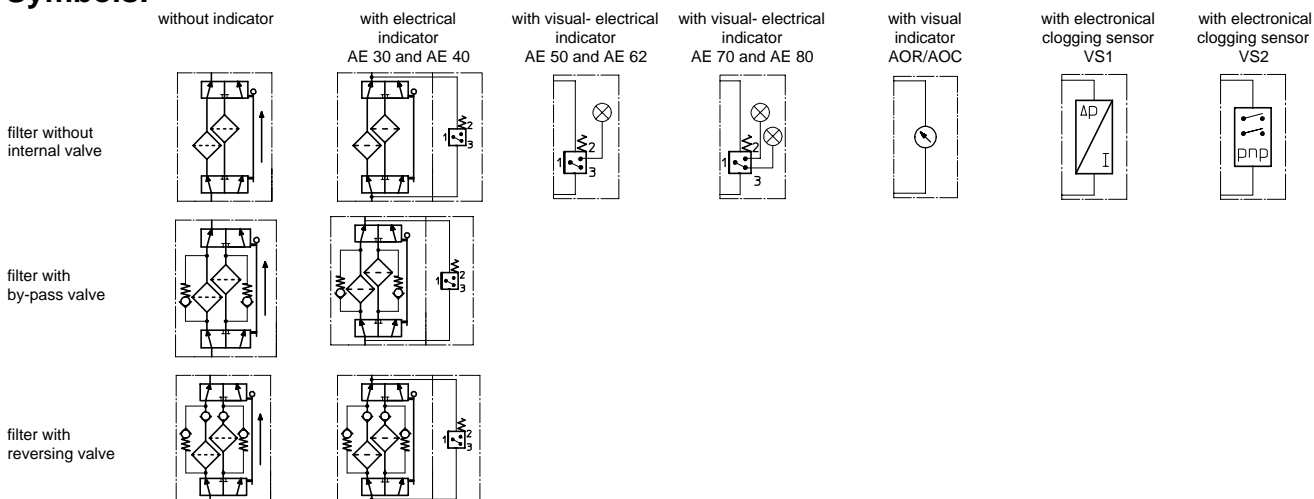

8. Pressure drop flow curves:

Precise flow rates see 'INT-Expert-System Filter' respectively Δp -curves; depending on filter fineness and viscosity.

9. Test methods:

Filter elements are tested according to the following ISO standards:

ISO 2941	Verification of collapse/burst resistance
ISO 2942	Verification of fabrication integrity
ISO 2943	Verification of material compatibility with fluids
ISO 3723	Method for end load test
ISO 3724	Verification of flow fatigue characteristics
ISO 3968	Evaluation of pressure drop versus flow characteristics
ISO 16889	Multi-pass method for evaluating filtration performance