

PRESSURE FILTER, change-over

Series DU 631-1950

DN 65-80

PN 32

Sheet No.
2118 G

1. Type index:

1.1. Complete filter: (ordering example)

DU. 631. 10VG. 30. E. P. -. FS. 9. -. -. AE

1	2	3	4	5	6	7	8	9	10	11	12
---	---	---	---	---	---	---	---	---	----	----	----

- 1 series:
DU = pressure filter, change-over
- 2 nominal size: 631, 1001, 1950
- 3 filter-material and filter-fineness:
80 G = 80 µm, 40 G = 40 µm, 25 G = 25 µm stainless steel wire mesh,
25 VG = 20 µm_(c), 16 VG = 15 µm_(c), 10 VG = 10 µm_(c), 6 VG = 7 µm_(c), 3 VG = 5 µm_(c) Interpor fleece (glass fibre)
25 P = 25 µm, 10 P = 10 µm paper
- 4 resistance of pressure difference for filter element:
30 = Δp 30 bar (01NL. 630) 10 = Δp 10 bar (01NR. 1000);
- 5 filter element design:
E = single-end open (DU 631) B = both sides open (DU 1001/1950)
S = with by-pass valve Δp 2,0 bar (DU 631) S1 = with by-pass valve Δp 3,5 bar (DU 631)
- 6 sealing material:
P = Nitrile (NBR) V = Viton (FPM)
- 7 filter element specification: (see catalog)
- = standard VA = stainless steel IS06 = see sheet-no. 31601 IS07 = see sheet-no. 31602
- 8 connection:
FS = SAE-flange connection 3000 PSI
- 9 connection size:
9 = 2 1/2" (DU 631) A = 3" (DU 1001/1950)
- 10 filter housing specification: (see catalog)
- = standard IS06 = see sheet-no. 31605 IS12 = see sheet-no. 41028
- 11 internal valve:
- = without
S = with by-pass valve Δp 2,0 bar (DU 1001/1950)
S1 = with by-pass valve Δp 3,5 bar (DU 1001/1950)
- 12 clogging indicator or clogging sensor:
- = without, OP = visual, see sheet-no. 1628
AOR = visual, see sheet-no. 1606, OE = visual-electrical, see sheet-no. 1628
AOC = visual, see sheet-no. 1606, VS1 = electrical, see sheet-no. 1607
AE = visual-electrical, see sheet-no. 1609, VS2 = electrical, see sheet-no. 1608

1.2. Filter element: (ordering example)

01NL. 630. 10VG. 30. E. P. -

1	2	3	4	5	6	7
---	---	---	---	---	---	---

- 1 series:
01NL = standard filter element according to DIN 24550, T3
01NR = standard-return-line filter element according to DIN 24550, T4
- 2 nominal size: 630 (01NL.), 1000 (01NR.)
- 3 - 7 see type index-complete filter

2. Accessories:

- measure- and bleeder connections, see sheet-no. 1650
- evacuation and bleeder-connections, see sheet-no. 1651
- counter flanges, see sheet-no. 1652
- shut-off valve, see sheet-no. 1655

3. Dimensions:

type	connection	SAE-connection size	A	B	C	D	E	F	G	H	J	K	L	M	N	O	P	Q	R	S	T	weight kg
DU 631	DN 65	SAE 2 1/2"	693	568	497	110	115	24	160	284	120	121	83	140	115	210	185	13,5	50,8	89	M12, 18 deep	90
DU 1001	DN 80	SAE 3"	717	586	505	93,5	140	28,5	205	380	142	137	101	210	170	265	225	18	62	106,4	M16, 23 deep	116
DU 1950	DN 80	SAE 3"	1119	988	907	93,5	140	28,5	205	380	142	137	101	210	170	265	225	18	62	106,4	M16, 23 deep	170

Changes of measures and design are subject to alteration!

internormen
technology

Friedensstrasse 41, 68804 Altlusheim, Germany

phone +49 - (0)6205 - 2094-0 e-mail sales@internormen.com
fax +49 - (0)6205 - 2094-40 url www.internormen.com

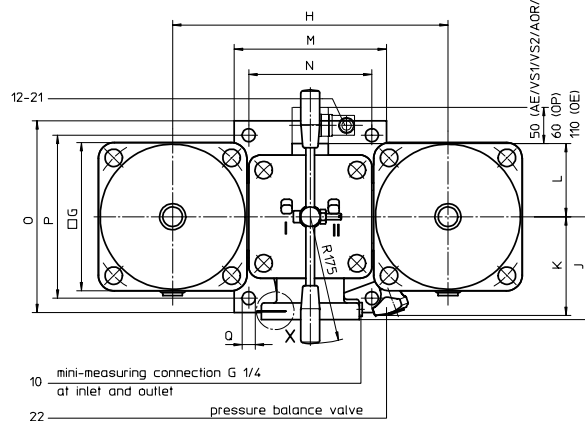
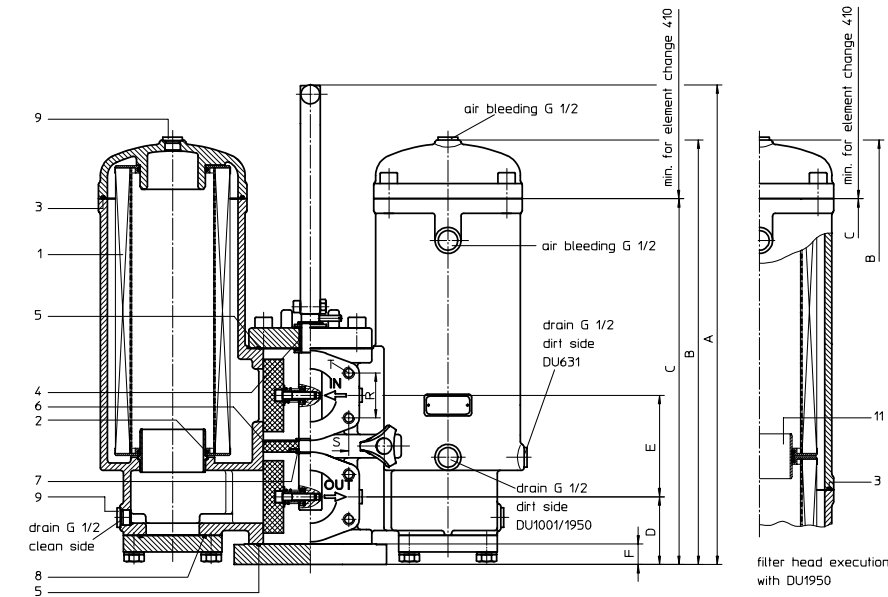

detail X

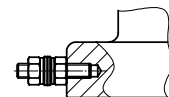

connection for the potential equalisation at outlet, only for application in the explosive area

Pos. I: left filter-side in operation
Pos. II: right filter-side in operation

4. Spare parts:

item	designation	qty.	dimension and article-no. DU 631	qty.	dimension and article-no. DU 1001	qty.	dimension and article-no. DU 1950
1	filter element	2	01NL 630	2	01NR 1000	4	01NR 1000
2	O-ring	2	60 x 3,5 304377 (NBR) 304398 (FPM)	4	90 x 4 306941 (NBR) 307031 (FPM)	8	90 x 4 306941 (NBR) 307031 (FPM)
3	O-ring	2	125 x 3 306025 (NBR) 307358 (FPM)	2	185 x 4 305593 (NBR) 306309 (FPM)	4	185 x 4 305593 (NBR) 306309 (FPM)
4	O-ring	1	24 x 3 303038 (NBR) 304397 (FPM)	24 x 3 303038 (FPM) 304397 (FPM)			
5	O-ring	2	115 x 3 303963 (NBR) 307762 (FPM)	140 x 3 304604 (NBR) 307541 (FPM)			
6	O-ring	1	96 x 4 305190 (NBR) 308148 (FPM)	120 x 4 305300 (NBR) 307991 (FPM)			
7	O-ring	1	32 x 2,5 306843 (NBR) 308268 (FPM)	32 x 2,5 306843 (NBR) 308268 (FPM)			
8	O-ring	2	69,45 x 3,53 305868 (NBR) 307357 (FPM)	85,32 x 3,53 305590 (NBR) 306308 (FPM)			
9	screw plug	8	G ½ 304678	8	G ½ 304678	10	G ½ 304678
10	screw plug	2	G ¼ 305003				
11	connecting pipe	2	Ø 90 313233				
12	clogging indicator, visual	1	AOR or AOC see sheet-no. 1606				
13	clogging indicator, visual	1	OP see sheet-no. 1628				
14	clogging indicator, visual-electrical	1	OE see sheet-no. 1628				
15	clogging indicator, visual-electrical	1	AE see sheet-no. 1609				
16	clogging sensor, electronical	1	VS1 see sheet-no. 1607				
17	clogging sensor, electronical	1	VS2 see sheet-no. 1608				
18	O-ring	1	15 x 1,5 315357 (NBR) 315427 (FPM)				
19	O-ring	1	22 x 2 304708 (NBR) 304721 (FPM)				
20	O-ring	2	14 x 2 304342 (NBR) 304722 (FPM)				
21	screw plug	2	G ¼ 305003				
22	pressure balance valve	1					

item 21 execution only without clogging indicator or clogging sensor

5. Description:

Pressure filters, change-over series DU 631-1950 are suitable for operating pressure up to 32 bar.

Pressure peaks can be absorbed with a sufficient margin of safety.

A three-way-change-over valve which is, integrated in the middle of the housing, makes it possible to switch from the dirty filter-side to the clean filter-side without interrupting operation.

These filters can be installed as suction filters, pressure filters or return-line filters.

The filter element consists of star-shaped, pleated filter material which is supported on the inside by a perforated core tube and is bonded to the end caps with a high-quality adhesive. The flow direction is from outside to the inside.

Filter finer than 40 µm should use throw-away elements made of paper or Interpor fleece (glass fibre). Filter elements as fine as 5 µm are available; finer filter elements on request.

INTERNORMEN-Filter elements are known as elements with a high intrinsic stability and an excellent filtration capability, a high dirt-retaining capacity and a long service life.

INTERNORMEN-Filter are suitable for all petroleum based fluids, HW-emulsions, most synthetic hydraulic fluids and lubrication oils.

Approvals according to TÜV, and the major „Shipyards Classification Societies“ D.N.V.; B.V.; G.L.; L.R.S.; R.I.N.A.; A.B.S. and others are possible.

The internal valve is integrated in the filter cover. After reaching the opening pressure the by-pass valve causes that an unfiltered partial flow passes the filter.

6. Technical data:

temperature range:	- 10°C to + 80°C (for a short time + 100°C)
operating medium:	mineral oil, other media on request
max. operating pressure:	32 bar
test pressure:	64 bar
connection system:	SAE-flange connection 3000 PSI
housing material:	EN-GJS-400-18-LT
sealing material:	Nitrile (NBR) or Viton (FPM), other materials on request
installation position:	vertical
mini-measuring connections:	G ¼
evacuation-or bleeder connections:	G ½
volume tank DU 631:	2x 5,7 l
DU 1001:	2x 13,0 l
DU 1950:	2x 23,3 l

Classified under the Pressure Equipment Directive 97/23/EC for mineral oil (fluid group 2), Article 3, Para. 3.

Classified under ATEX Directive 94/9/EC according to specific application (see questionnaire sheet-no. 34279-4)

7. Symbols:

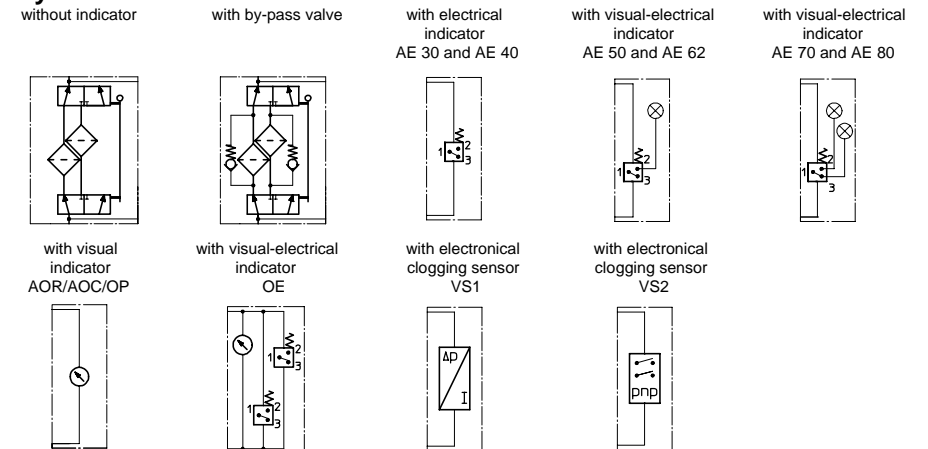

8. Pressure drop flow curves:

Precise flow rates see 'INT-Expert-System Filter', respectively Δp- curves; depending on filter fineness and viscosity.

9. Test methods:

Filter elements are tested according to the following ISO standards:

ISO 2941	Verification of collapse/burst resistance
ISO 2942	Verification of fabrication integrity
ISO 2943	Verification of material compatibility with fluids
ISO 3723	Method for end load test
ISO 3724	Verification of flow fatigue characteristics
ISO 3968	Evaluation of pressure drop versus flow characteristics
ISO 16889	Multi-pass method for evaluating filtration performance