

**PRESSURE FILTER, change-over**  
**Series DU 63 DN 20 PN 32**

Sheet No.  
**2121 K**

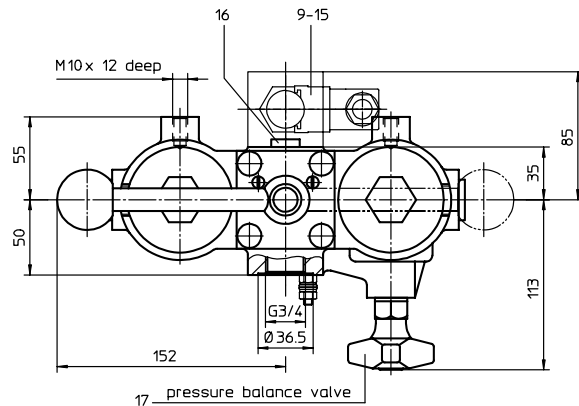
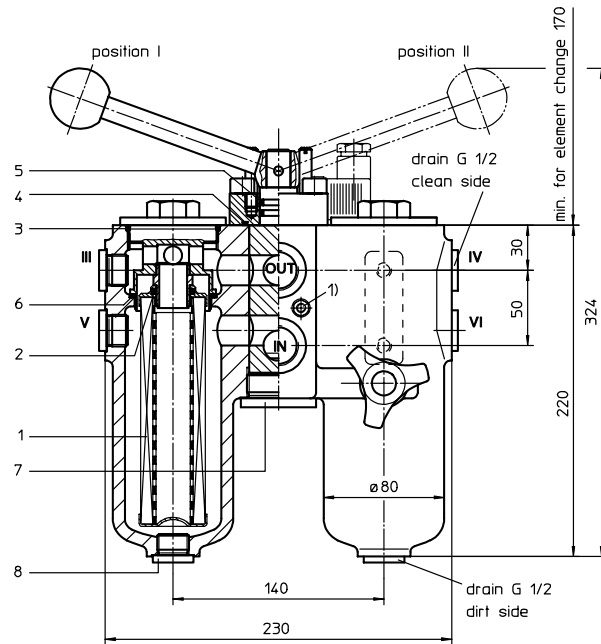

1) connection for the potential equalisation,  
 only for application in the explosive area

Pos. I: left filter-side in operation  
 Pos. II: right filter-side in operation

measure connection III, IV: air bleeding, pressure relief G 1/2 - clean side  
 measure connection V, VI: air bleeding, pressure relief G 1/2 - dirt side

**1. Type index:**

**1.1. Complete filter: (ordering example)**

**DU. 63. 10VG. 30. E. P. -. G. 4. -. -. AE**

1	2	3	4	5	6	7	8	9	10	11	12
---	---	---	---	---	---	---	---	---	----	----	----

- 1 series:  
DU = pressure filter, change-over
- 2 nominal size: 63
- 3 filter-fineness and filter-material:  
80 G = 80 µm, 40 G = 40 µm, 25 G = 25 µm stainless steel wire mesh,  
25 VG = 20 µm<sub>(ci)</sub>, 16 VG = 15 µm<sub>(ci)</sub>, 10 VG = 10 µm<sub>(ci)</sub>, 6 VG = 7 µm<sub>(ci)</sub>, 3 VG = 5 µm<sub>(ci)</sub> Interpor fleece (glass fibre)  
25 P = 25 µm, 10 P = 10 µm paper
- 4 resistance of pressure difference for filter element:  
30 = Δp 30 bar
- 5 filter element design:  
E = single-end open
- 6 sealing material:  
P = Nitrile (NBR)  
V = Viton (FPM)
- 7 filter element specification:  
- = standard  
VA = stainless steel
- 8 connection:  
G = thread connection according to ISO 228
- 9 connection size:  
4 = G 3/4
- 10 filter housing specification:  
- = standard
- 11 internal valve:  
- = without  
S1 = with by-pass valve Δp 3,5 bar
- 12 clogging indicator or clogging sensor:  
- = without  
AOR = visual, see sheet-no. 1606  
AOC = visual, see sheet-no. 1606  
AE = visual-electrical, see sheet-no. 1615  
VS1 = electrical, see sheet-no. 1617  
VS2 = electrical, see sheet-no. 1618

**1.2. Filter element: (ordering example)**

**01NL. 63. 10VG. 30. E. P. -**

1	2	3	4	5	6	7
---	---	---	---	---	---	---

- 1 series:  
01NL = standard filter element according to DIN 24550, T3
- 2 nominal size: 63
- 3 - 7 see type index-complete filter

**2. Accessories:**

- measure- and bleeder-connections, see sheet-no. 1650
- evacuation- and bleeder-connections, see sheet-no. 1651

weight: 15 kg

Changes of measures and design are subject to all eration!



Friedensstrasse 41, 68804 Altlusheim, Germany

phone +49 - (0)6205 - 2094-0 e-mail sales@internormen.com  
 fax +49 - (0)6205 - 2094-40 url www.internormen.com



### 3. Spare parts:

item	qty.	designation	dimension	article-no.	
1	2	filter element	01NL 63		
2	2	O-ring	22 x 3,5	304341 (NBR)	304392 (FPM)
3	2	O-ring	56 x 3	305072 (NBR)	305322 (FPM)
4	1	O-ring	42,52 x 2,62	304352 (NBR)	304393 (FPM)
5	2	O-ring	18 x 3	304359 (NBR)	304399 (FPM)
6	2	O-ring	48 x 3	304357 (NBR)	304404 (FPM)
7	1	screw plug	G 1 ¼	308530	
8	6	screw plug	G ½	304678	
9	1	clogging indicator, visual	AOR or AOC	see sheet-no. 1606	
10	1	clogging indicator, visual-electrical	AE	see sheet-no. 1615	
11	1	clogging sensor, electronical	VS1	see sheet-no. 1617	
12	1	clogging sensor, electronical	VS2	see sheet-no. 1618	
13	1	O-ring	15 x 1,5	315357 (NBR)	315427 (FPM)
14	1	O-ring	22 x 2	304708 (NBR)	304721 (FPM)
15	3	O-ring	14 x 2	304342 (NBR)	304722 (FPM)
16	2	screw plug	G ¼	305003	
17	1	pressure balance valve			

item 16 execution only without clogging indicator or clogging sensor

### 4. Description:

Pressure filter of the series DU 63 are suitable for a working pressure up to 32 bar.

The pressure peaks are absorbed by a sufficient margin of safety.

Rotary slide valve which is integrated in the middle of the housing makes it possible to switch from the dirty filter-side to the clean filter-side without interrupting operation. These filters can be installed as suction-filters.

The filter element consist of star-shaped, pleated filter material which is supported on the inside by a perforated core tube and is bonded to the end caps with a high-quality adhesive. The flow direction is from outside to the inside.

Filter finer than 40 µm should use throw-away elements made of paper or Interpor fleece (glass fibre).

Filter elements as fine as 5 µm<sub>(c)</sub> are available; finer filter elements on request.

INTERNORMEN-Filter elements are known as elements with a high intrinsic stability and an excellent filtration capability, a high dirt-retaining capacity and a long service life.

INTERNORMEN-Filter are suitable for all petroleum based fluids, HW-emulsions, most synthetic hydraulic fluids and lubrication oils.

Approvals according to TÜV, and the major „Shipyards Classification Societies“ D.N.V.; B.V.; G.L.; L.R.S.; R.I.N.A.; A.B.S. and others are possible.

The internal valve is integrated in the filter cover. After reaching the opening pressure the by-pass valve causes that an unfiltered partial flow passes the filter.

### 5. Technical data:

temperature range:	- 10°C to + 80°C (for a short time + 100°C)
operating medium:	mineral oil, other media on request
max. operating pressure:	32 bar
test pressure:	64 bar
connection system:	thread connection according to ISO 228
housing material:	EN-GJS-400-18-LT
sealing material:	Nitrile (NBR) or Viton (FPM), other materials on request
installation position:	vertical
mini-measuring connections:	G ½
evacuation-or bleeder connections:	G ½
volume tank:	2x 0,65 l

Classified under the Pressure Equipment Directive 97/23/EC for mineral oil (fluid group 2), Article 3, Para. 3.

Classified under ATEX Directive 94/9/EC according to specific application (see questionnaire sheet-no. 34279-4).

### 6. Symbols:

without indicator

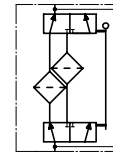

with by-pass valve

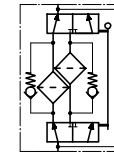

with electrical indicator  
AE 30 and AE 40

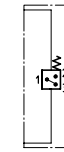

with visual-electrical indicator  
AE 50 and AE 62

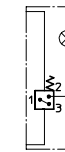

with visual-electrical indicator  
AE 70 and AE 80

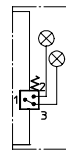

with visual indicator  
OP

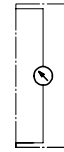

with visual-electrical indicator  
OE

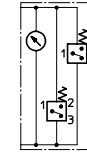

with electronical clogging sensor  
VS1

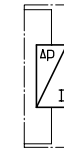

with electronical clogging sensor  
VS2



### 7. Pressure drop flow curves:

Precise flow rates see 'INT-Expert-System Filter', respectively Δp- curves; depending on filter fineness and viscosity.

### 8. Test methods:

Filter elements are tested according to the following ISO standards:

- ISO 2941 Verification of collapse/burst resistance
- ISO 2942 Verification of fabrication integrity
- ISO 2943 Verification of material compatibility with fluids
- ISO 3723 Method for end load test
- ISO 3724 Verification of flow fatigue characteristics
- ISO 3968 Evaluation of pressure drop versus flow characteristics
- ISO 16889 Multi-pass method for evaluating filtration performance