

PRESSURE FILTER, change-over
Series DNA 250-630 DN 50-65 PN 16

Sheet No.
2137 H

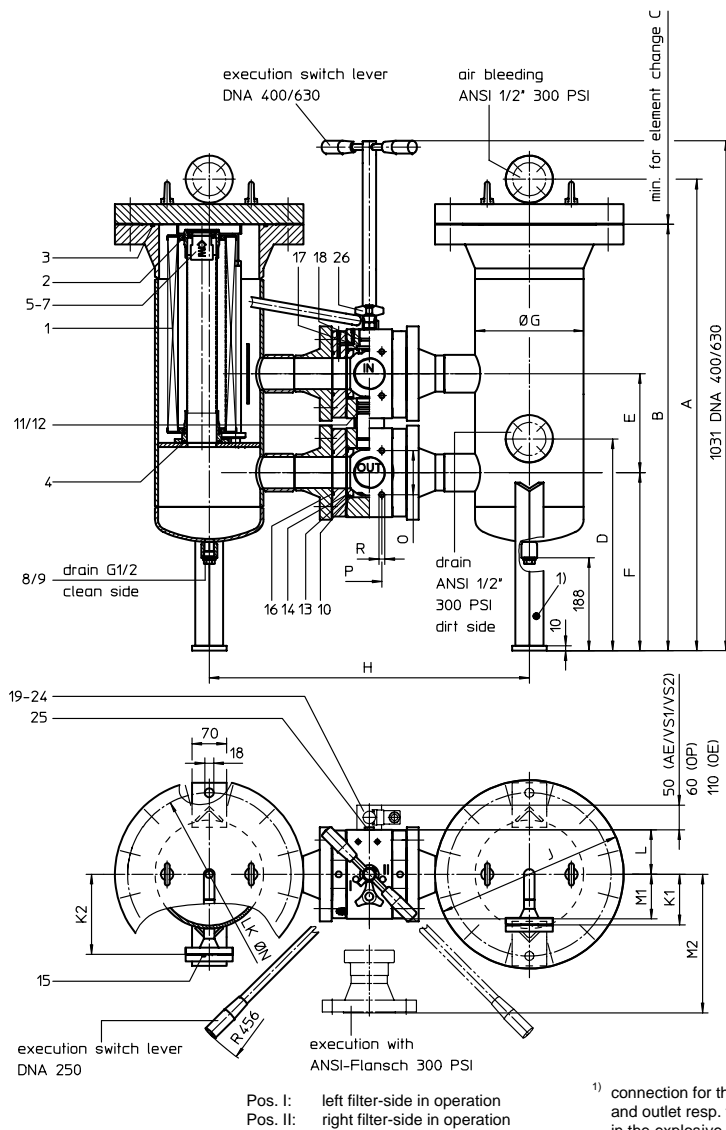

Pos. I: left filter-side in operation
 Pos. II: right filter-side in operation
 1) connection for the potential equalisation at inlet and outlet resp. filter housing, only for application in the explosive area

3. Dimensions:

type	connection	A	B	C	D	E	F	G	H	J	K1	K2	L	M1	M2	N	O	P	R	weight kg	volume tank
DNA 250	DN 50	821	715	270	433	175	365	168,3	603	317,5	82	136,5	74	74	191	278	42,9	77,8	M12x20 tief	223	2x 9 l
DNA 400	DN 65	847	756	270	472	200	360	219,1	647	381	102	162	90	90	218	330	52,8	89	M12x22 tief	264	2x 17 l
DNA 630	DN 65	953	862	420	428	200	360	219,1	647	381	102	162	90	90	218	330	52,8	89	M12x22 tief	272	2x 21 l

1. Type index:

1.1. Complete filter: (ordering example)

DNA. 630. 10VG. 10. B. P. -. FS. 9. -. -. AE

1	2	3	4	5	6	7	8	9	10	11	12
---	---	---	---	---	---	---	---	---	----	----	----

- 1 series:
DNA = pressure filter, change-over according to ASME-code
- 2 nominal size: 250, 400, 630
- 3 filter-material and filter- fineness:
80 G = 80 µm, 40 G = 40 µm, 25 G = 25 µm stainless steel wire mesh
25 VG = 20 µm_(G), 16 VG = 15 µm_(G), 10 VG = 10 µm_(G), 6 VG = 7 µm_(G), 3 VG = 5 µm_(G) Interpor fleece (glass fibre)
- 4 resistance of pressure difference for filter element:
10 = Δp 10 bar
- 5 filter element design:
B = both sides open
- 6 sealing material:
P = Nitrile (NBR) V = Viton (FPM)
- 7 filter element specification:
- = standard VA = stainless steel
- 8 connection:
FS = SAE-flange connection 3000 PSI
FA = ANSI-flange connection 300 PSI
- 9 connection size:
8 = 2" (DNA 250)
9 = 2 1/2" (DNA 400/630)
- 10 filter housing specification:
- = standard
- 11 internal valve:
- = without
S1 = with by-pass valve Δp 3,5 bar S2 = with by-pass valve Δp 7,0 bar
- 12 clogging indicator or clogging sensor:
- = without
AE = visual-electrical, see sheet-no. 1609
OP = visual, see sheet-no. 1628 VS1 = electronical, see sheet-no. 1607
OE = visual-electrical, see sheet-no. 1628 VS2 = electronical, see sheet-no. 1608

1.2. Filter element: (ordering example)

01NR. 630. 10VG. 10. B. P. -

1	2	3	4	5	6	7
---	---	---	---	---	---	---

- 1 series:
01NR. = standard-return-line filter element according to DIN 24550, T4
- 2 nominal size: 250, 400, 630
- 3 - 7 see type index-complete filter

2. Accessories:

- shut-off valve see sheet-no. 1655
- SAE-counter-flange see sheet-no. 1652
- adaptor for ANSI-flange 300 PSI see sheet-no. 1658

Changes of measures and design are subject to alteration!



Friedensstrasse 41, 68804 Altlusheim, Germany

phone +49 - (0)6205 - 2094-0 e-mail sales@internormen.com
 fax +49 - (0)6205 - 2094-40 url www.internormen.com



4. Spare parts:

item	designation	qty.	dimension and article-no. DNA 250	dimension and article-no. DNA 400	dimension and article-no. DNA 630
1	filter element	2	01NR. 250	01NR. 400	01NR. 630
2	O-ring	4	52 x 3 314206 (NBR) 316698 (FPM)	70 x 4 306253 (NBR) 310280 (FPM)	
3	O-ring	2	170 x 6 304799 (NBR) 306529 (FPM)	225 x 5 308652 (NBR) 311473 (FPM)	
4	O-ring	2	47,22 x 3,53 305078 (NBR) 310269 (FPM)	68 x 5 304376 (NBR) 304394 (FPM)	
5	by-pass valve	2	DN 20	DN 32	
6	O-ring	2	28 x 3 316778 (NBR) 318366 (FPM)	45 x 3 304991 (NBR) 304997 (FPM)	
7	circlip	1	DIN 472-38x1,5 311921	DIN 472-57x5 317668	
8	screw plug	2	G ¼ 309730	G ¼ 309730	
9	gasket	2	A 22 x 27 305564	A 22 x 27 305564	
10	O-ring	4	76 x 4 305599 (NBR) 310291 (FPM)	95 x 3 305808 (NBR) 304828 (FPM)	
11	O-ring	3	98 x 4 301914 (NBR) 304765 (FPM)	45 x 3 304991 (NBR) 304997 (FPM)	
12	support ring	3	103,4 x 97 x 5 318551	-	
13	gasket	4	DN 50 318549	DN 65 317651	
14	O-ring	4	56 x 3 305072 (NBR) 305322 (FPM)	85 x 4 305685 (NBR) 310285 (FPM)	
15	O-ring	4	22 x 3 304387 (NBR) 304931 (FPM)	22 x 3 304387 (NBR) 304931 (FPM)	
16	O-ring	4	63 x 3,5 311189 (NBR) 311592 (FPM)	82 x 3,5 304403 (NBR) 308745 (FPM)	
17	O-ring	4	-	8 x 2 310004 (NBR) 316530 (FPM)	
18	O-ring	4	-	34 x 3,5 304338 (NBR) 304730 (FPM)	
19	clogging indicator, visual-electrical	1		OE see sheet-no. 1628	
20	clogging indicator, visual	1		OP see sheet-no. 1628	
21	clogging indicator, visual-electrical	1		AE see sheet-no. 1609	
22	clogging sensor, electronical	1		VS1 see sheet-no. 1607	
23	clogging sensor, electronical	1		VS2 see sheet-no. 1608	
24	O-ring	2	14 x 2	304342 (NBR) 304722 (FPM)	
25	screw plug	2	G ¼	305003	
26	pressure balance valve	1			

Item 25 execution only without clogging indicator or clogging sensor

5. Description:

Pressure filters, change-over series DNA 250-630 are suitable for operating pressure up to 16 bar. Pressure peaks can be absorbed with a sufficient margin of safety. Change-over ball valve which integrated in the middle of the housing makes it possible to switch from the dirty filter-side to the clean filter-side without interrupting operation. The filter element consist of star-shaped, pleated filter material which is supported on the inside by a perforated core tube and is bonded to the end caps with a high-quality adhesive. The flow direction is from outside to the inside. These filters can be installed as suction filters. Filter finer than 40 µm should use throw-away elements made of paper or Interpor fleece (glass fibre). Filter elements as fine as 5 µm_(c) are available; finer filter elements on request. INTERNORMEN-Filter elements are known as elements with a high intrinsic stability and an excellent filtration capability, a high dirt-retaining capacity and a long service life. INTERNORMEN-Filter are suitable for all petroleum based fluids, HW-emulsions, most synthetic hydraulic fluids and lubrication oils. Approvals according to TÜV, and the major „Shipyards Classification Societies“ D.N.V.; B.V.; G.L.; L.R.S.; R.I.N.A.; A.B.S. and others are possible. The internal valve is integrated in the filter. After reaching the opening pressure the by-pass valve causes that an unfiltered partial flow passes the filter.

6. Technical data:

temperature range: - 10°C to + 80°C (for a short time + 100°C)
operating medium: mineral oil, other media on request
max. operating pressure: 16 bar
test pressure: 24 bar
connection system: SAE-flange 3000 PSI or ANSI-flange 300 PSI
housing material: C-steel
sealing material: Nitrile (NBR) or Viton (FPM), other materials on request
installation position: vertical
calculation according to: ASME-code, sec. VIII / div. 1 - 1998; add.98

Classified under the Pressure Equipment Directive 97/23/EC for mineral oil (fluid group 2), Article 3, Para. 3.
Classified under ATEX Directive 94/9/EC according to specific application (see questionnaire sheet-no. 34279-4).

7. Symbols:

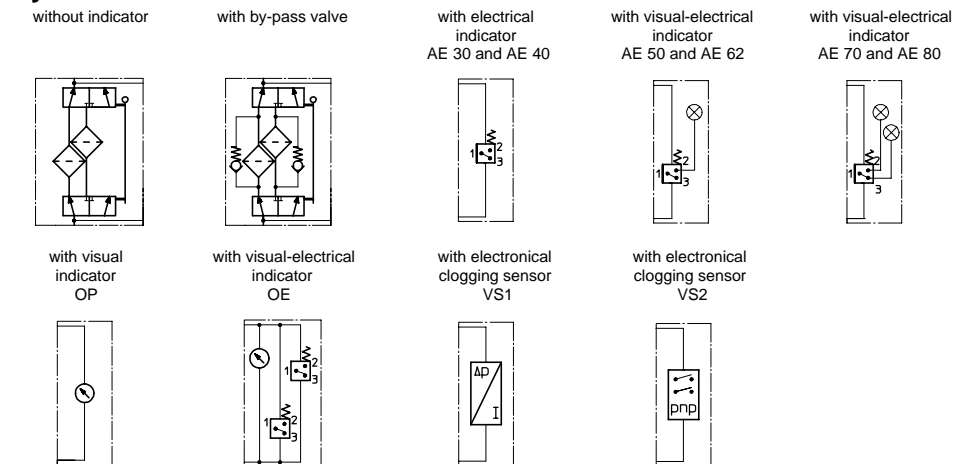

8. Pressure drop flow curves:

Precise flow rates see 'INT-Expert-System Filter', respectively Δp-curves; depending on filter fineness and viscosity.

9. Test methods:

Filter elements are tested according to the following ISO standards:

ISO 2941 Verification of collapse/burst resistance
ISO 2942 Verification of fabrication integrity
ISO 2943 Verification of material compatibility with fluids
ISO 3723 Method for end load test
ISO 3724 Verification of flow fatigue characteristics
ISO 3968 Evaluation of pressure drop versus flow characteristics
ISO 16889 Multi-pass method for evaluating filtration performance