

PRESSURE FILTER, change-over
Series DNA 1050-2050 DN 100 PN 16

Sheet No.
2138 H

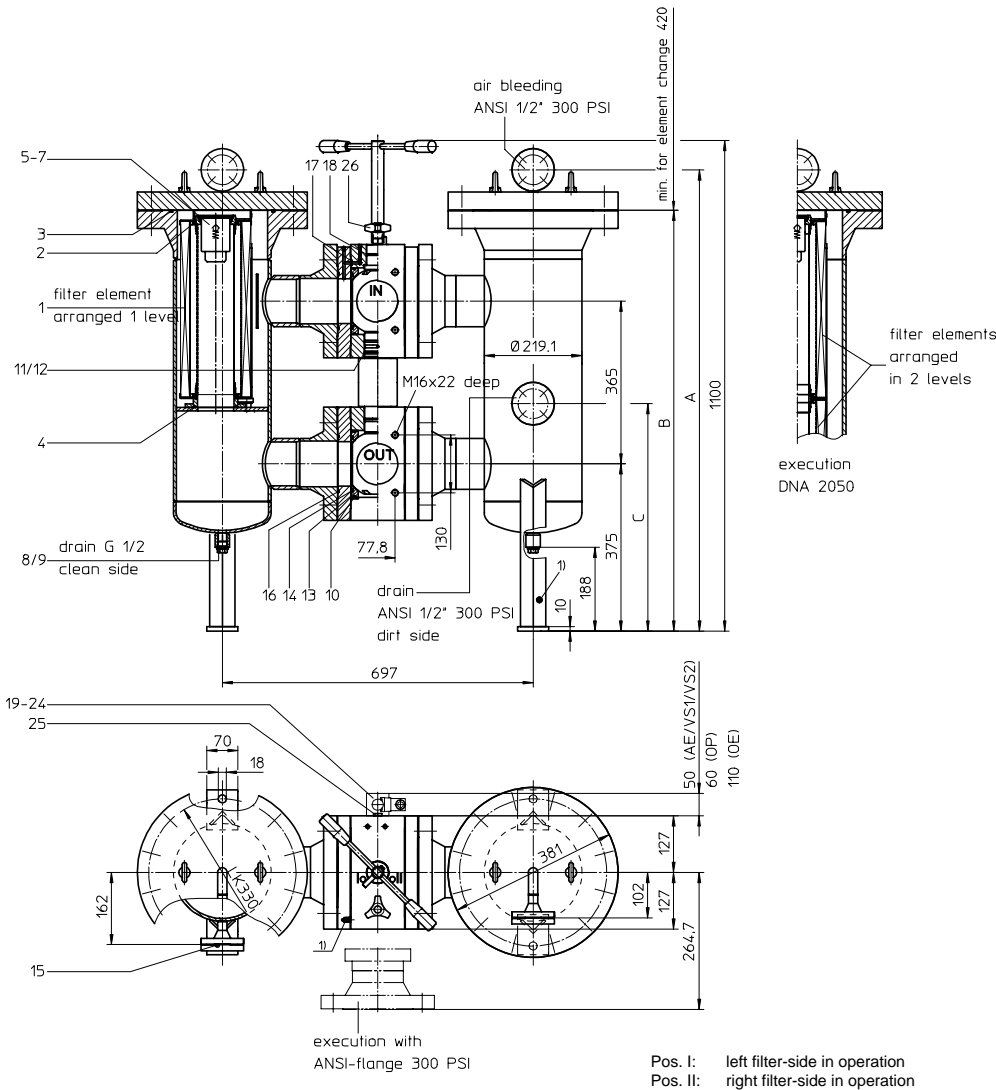

Pos. I: left filter-side in operation
 Pos. II: right filter-side in operation
 1) connection for the potential equalisation at inlet and outlet resp. filter housing, only for application in the explosive area

3. Dimensions:

type	connection	A	B	C	weight kg	volume tank
DNA 1050	DN 100	1035	944	510	446	2x 24 l
DNA 2050	DN 100	1391	1300	467	476	2x 35 l

1. Type index:

1.1. Complete filter: (ordering example)

DNA. 1050. 10VG. 10. B. P. -. FS. B. -. -. AE

1	2	3	4	6	6	7	8	9	10	11	12
---	---	---	---	---	---	---	---	---	----	----	----

- 1 | **series:**
DNA = pressure filter, change-over according to ASME-code
- 2 | **nominal size:** 1050, 2050
- 3 | **filter-material and filter-fineness:**
80 G = 80 µm, 40 G = 40 µm, 25 G = 25 µm stainless steel wire mesh
25 VG = 20 µm_(c), 16 VG = 15 µm_(c), 10 VG = 10 µm_(c), 6 VG = 7 µm_(c), 3 VG = 5 µm_(c) Interpor fleece (glass fibre)
- 4 | **resistance of pressure difference for filter element:**
10 = Δp 10 bar
- 5 | **filter element design:**
B = both sides open
- 6 | **sealing material:**
P = Nitrile (NBR)
V = Viton (FPM)
- 7 | **filter element specification:**
- = standard
VA = stainless steel
- 8 | **connection:**
FS = SAE-flange connection 3000 PSI
FA = ANSI-flange connection 300 PSI
- 9 | **connection size:**
B = 4"
- 10 | **filter housing specification:**
- = standard
- 11 | **internal valve:**
- = without
S1 = with by-pass valve Δp 3,5 bar
S2 = with by-pass valve Δp 7,0 bar
- 12 | **clogging indicator or clogging sensor:**
- = without
AE = visual-electrical, see sheet-no. 1609
OP = visual, see sheet-no. 1628
OE = visual-electrical, see sheet-no. 1628
VS1 = electronic, see sheet-no. 1607
VS2 = electronic, see sheet-no. 1608

1.2. Filter element: (ordering example)

01NR. 1000. 10VG. 10. B. P. -

1	2	3	4	5	6	7
---	---	---	---	---	---	---

- 1 | **series:**
01NR. = standard-return-line filter element according to DIN 24550, T4
- 2 | **nominal size:** 1000
- 3 | - 7 | see type index-complete filter

2. Accessories:

- shut-off valve, see sheet-no. 1655
- SAE-counter-flange see sheet-no. 1652
- adaptor for ANSI-flange 300 PSI, see sheet-no. 1658

Changes of measures and design are subject to alteration!



Friedensstrasse 41, 68804 Altlusheim, Germany

phone +49 - (0)6205 - 2094-0 e-mail sales@internormen.com
 fax +49 - (0)6205 - 2094-40 url www.internormen.com



4. Spare parts:

item	designation	qty.	dimension and article-no. DNA 1050	qty.	dimension and article-no. DNA 2050
1	filter element	2	01NR. 1000	4	01NR. 1000
2	O-ring	4	90 x 4 306941 (NBR) 307031 (FPM)	8	90 x 4 306941 (NBR) 307031 (FPM)
3	O-ring	2	225 x 5 308652 (NBR) 311473 (FPM)		
4	O-ring	2	90 x 4 306941 (NBR) 307031 (FPM)		
5	by-pass valve	2	DN 50	311470	
6	O-ring	2	62 x 4 308045 (NBR) 311472 (FPM)		
7	circlip	2	DIN 472-75x2,5	311471	
8	screw plug	2	G ½	309730	
9	gasket	2	A 22 x 27	310476	
10	O-ring	4	140 x 4 305145 (NBR) 305201 (FPM)		
11	O-ring	3	54 x 3 304657 (NBR) 304720 (FPM)		
12	sliding ring	2	087 x 060 x 1,5	318100	
13	gasket	4	DN 90	312275	
14	O-ring	4	114 x 6 314419 (NBR) 316531 (FPM)		
15	O-ring	4	22 x 3 304387 (NBR) 304931 (FPM)		
16	O-ring	4	120 x 4 305300 (NBR) 307991 (FPM)		
17	O-ring	2	8 x 2 310004 (NBR) 316530 (FPM)		
18	O-ring	1	45 x 3 304991 (NBR) 304997 (FPM)		
19	clogging indicator visual-electrical	1	OE	see sheet-no. 1628	
20	clogging indicator visual	1	OP	see sheet-no. 1628	
21	clogging indicator visual-electrical	1	AE	see sheet-no. 1609	
22	clogging sensor electronical	1	VS1	see sheet-no. 1607	
23	clogging sensor electronical	1	VS2	see sheet-no. 1608	
24	O-ring	2	14 x 2 304342 (NBR) 304722 (FPM)		
25	screw plug	2	G ¼	305003	
26	pressure balance valve	1			

Item 25 execution only without clogging indicator or clogging sensor

5. Description:

Pressure filters, change-over series DNA 1050-2050 are suitable for operating pressure up to 16 bar. Pressure peaks can be absorbed with a sufficient margin of safety.

Change-over ball valve which, integrated in the middle of the housing, makes it possible to switch from the dirty filter-side to the clean filter-side without interrupting operation.

The filter element consists of star-shaped, pleated filter material which is supported on the inside by a perforated core tube and is bonded to the end caps with a high-quality adhesive. The flow direction is from outside to the inside. These filters can be installed as suction filters.

Filter finer than 40 µm should use throw-away elements made of paper or Interpor fleece (glass fibre). Filter elements as fine as 5 µm₀ are available; finer filter elements on request.

INTERNORMEN-Filter elements are known as elements with a high intrinsic stability and an excellent filtration capability, a high dirt-retaining capacity and a long service life.

INTERNORMEN-Filter are suitable for all petroleum based fluids, HW-emulsions, most synthetic hydraulic fluids and lubrication oils.

Approvals according to TÜV, and the major „Shipyards Classification Societies“ D.N.V.; B.V.; G.L.; L.R.S.; R.I.N.A.; A.B.S. and others are possible.

The internal valve is integrated into the filter. After reaching the opening pressure the by-pass valve causes that an unfiltered partial flow passes the filter.

6. Technical data:

temperature range:
operating medium:
max. operating pressure:
test pressure:
connection system:
housing material:
sealing material:
installation position:
calculation according to:

- 10°C to + 80°C (for a short time + 100°C)
mineral oil, other media on request
16 bar
24 bar
SAE-flange 3000 PSI or ANSI-flange 300 PSI
C-steel
Nitrile (NBR) or Viton (FPM), other materials on request
vertical
ASME-code, sec. VIII / div.1 - 1998; add.98

Classified under the Pressure Equipment Directive 97/23/EC for mineral oil (fluid group 2), Article 3, Para. 3.
Classified under ATEX Directive 94/9/EC according to specific application (see questionnaire sheet-no. 34279-4).

7. Symbols:

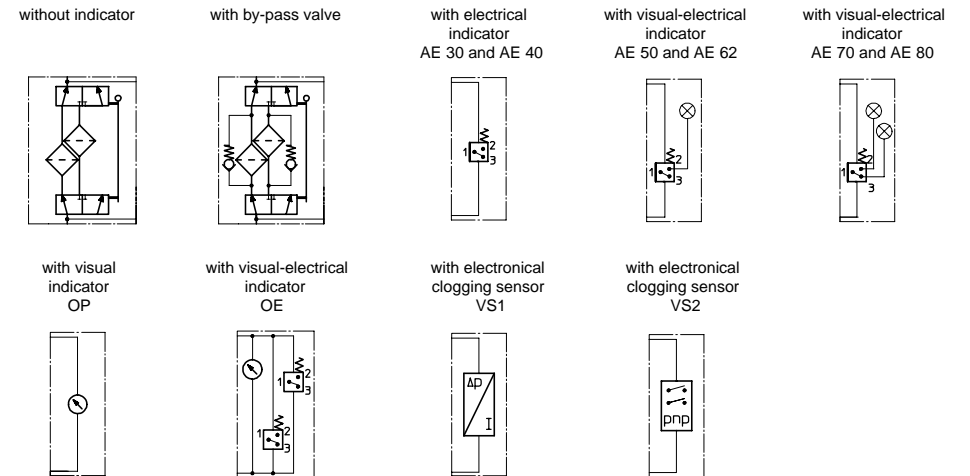

8. Pressure drop flow curves:

Precise flow rates see 'INT-Expert-System Filter', respectively Δp-curves; depending on filter fineness and viscosity.

9. Test methods:

Filter elements are tested according to the following ISO standards:

ISO 2941	Verification of collapse/burst resistance
ISO 2942	Verification of fabrication integrity
ISO 2943	Verification of material compatibility with fluids
ISO 3723	Method for end load test
ISO 3724	Verification of flow fatigue characteristics
ISO 3968	Evaluation of pressure drop versus flow characteristics
ISO 16889	Multi-pass method for evaluating filtration performance