



## InterPro

### IFH - Filter Housings

#### Filter Housings

- High quality
- Three parts version
- For DOE and SOE filter cartridges

Three part filter housing with clamp connection.  
Available for 10", 20", 30", 40" cartridges.

#### Product Specifications

<b>Material Vessel</b> .....	SS 316
<b>Material Gasket</b> .....	Silicone (other materials optional)
<b>Vents (N3)</b> .....	BSP 1/4" (female)
<b>In- / Outlet (N1+N2)</b> .....	BSP 3/4" and 1" (female), weld outer diameter 33,7 x 1,85mm
<b>Drain (N4)</b> .....	BSP 1/4" (male)
<b>Operating Pressure max.</b> .....	8 bar (116 psi) at 40°C (104°F) 6,2 bar (90 psi) at 150°C (302°F)
<b>Available housing length</b> .....	10", 20", 30", 40"
<b>Surface Finish</b> .....	Internal: Pickled External: Mechanically polished
<b>Holder (optional)</b> .....	Zinc plated steel

#### Cartridge Dimensions

the following filter cartridges can be used in IFH-housings:  
 IFH 1 = DOE (248 to 256 mm), SOE 10" Code 3 or Code 7  
 IFH 2 = DOE (496 to 508 mm), SOE 20" Code 3 or Code 7  
 IFH 3 = DOE (744 to 762 mm), SOE 30" Code 3 or Code 7  
 IFH 4 = DOE (1012 to 1016 mm), SOE 40" Code 3 or Code 7



Housing type	Dimensions (mm)			
	A	B	change out	Volume (l)
IFH 1	382	320	300	1,8
IFH 2	637	575	554	3,3
IFH 3	892	830	808	4,8
IFH 4	1147	1085	1062	6,3

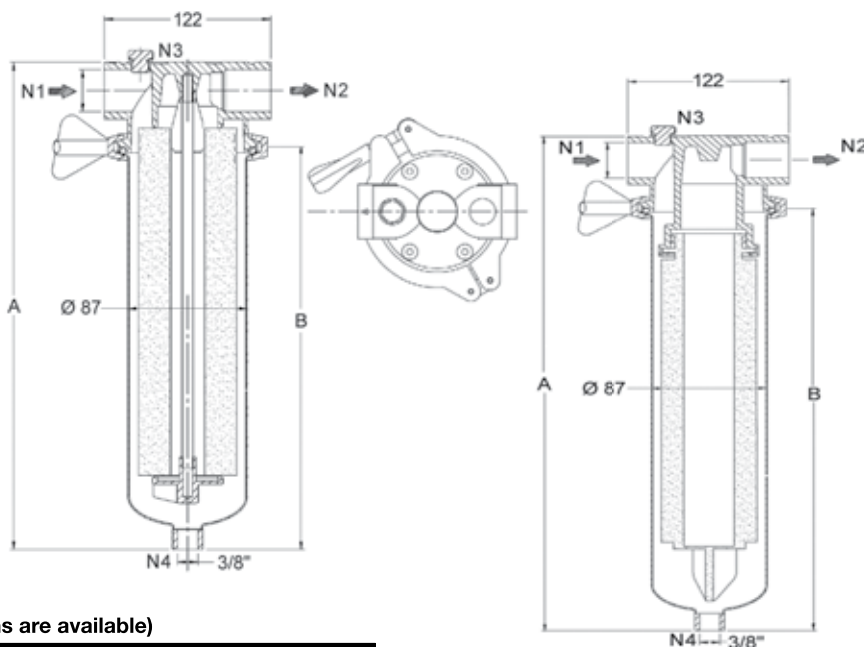

#### Ordering Information (universal ordering code, not all options are available)

IFH	Nominal Length Code	Connection Code	Connection Type	Cartridge Type Code	Seals
	1 = 10"	A = 3/4" 20	C = Tri-clamp	1 = DOE	S = Silicone
	2 = 20"	B = 1" 25	H = Heavy clamp *	2 = SOE Code 7	
	3 = 30"	W = Weld		3 = SOE Code 3	
	4 = 40"				

\* Heavy clamp is suggested for steam use

#### Design Code:

Housings designed in accordance with the European Council Pressure Equipment Directive (PED)97/23/EC, complying Art. 3 Par. 3.  
Fluid Group 2